



Interiors  
with a story



The décor in our interior spaces tells the stories of our lives. Reflecting the memories we cherish, the pursuits we enjoy, our family history and all the things that interest or matter to us. With some pieces chosen for their tangible connection, others purely for their aesthetic appeal.

At Authentic Models, we combine the two through elegantly handcrafted furniture, objects and ornaments which capture the essence of an era or interest via meaningful and surprising design. Inspired by the adventurous spirit which led to many ingenious creations, our collections celebrate travel, exploration and endeavour. Treading in the footsteps of history while also exploring beyond the beaten track.

To complement the pieces which thoughtfully represent the past, we also create original new designs with a daring contemporary twist. Keeping time-honoured backstories alive in all kinds of ways, with character and quality that complements every personal style, to fit in with both modern and traditional settings.

Finally we would like to wish you a pleasant time exploring this catalogue.



# CONTENTS



FURNITURE	6
AVIATION	50
NAUTICAL	86
CARS	104
GLOBES	114
LIFESTYLE	130
INSTRUMENTS	156
HOW TO REACH US	181
INDEX	183



# FURNITURE

'Personalised travel' was taken quite literally at a time when the rich and famous, travelling by luxury steamer and staying in grand hotels, even brought their favourite furniture along. Given how special these pieces were, with their gorgeous crafting and ingenious functionality, it's not hard to appreciate why. Thanks to Authentic Models, you too can enjoy the charisma of high-end furniture from bygone times, through distinctive pieces which draw inspiration from glamorous eras. Complete with high quality finish, brass fittings and leather features that capture look & feel of the originals they're based on.



# Stateroom Bar

Fun and functionality coalescing into an impressive piece of historic proportions. Wheel in the bar. Park and lock it somewhere close at hand! Made in the style of turn-of-the-century travel trunks. Solid brass hardware and bridle leather accoutrements complete a hand-built, two-part bar inside a large trunk set on sturdy wheels.

A multitude of drawers, two serving trays, racks for both horizontal and vertical bottles. Mirror and foldout work shelf. Taking out the shelf unit on the right frees up a removable game board. Iconic. Confidently evocative of the Belle Époque when a hunt required only a Martini or a whiskey sour at hand!



Stateroom Bar, Burgundy / MF078Y

“Luxury is in each detail.”



**Stateroom Bar, Navy / MF078N**  
M. 59 x 62 x 147 cm, 23,20 x 24,40 x 57,90”



**Stateroom Bar, Black / MF078B**



**Stateroom Bar, Burgundy / MF078Y**  
M. 59 x 62 x 147 cm, 23,20 x 24,40 x 57,90”



**Stateroom Bar, Petrol / MF078P**

AUTHENTIC  
NEW  
MODELS

AUTHENTIC  
NEW  
MODELS

“Time to enjoy some drinks.”



**Bar Trolley / MF163**

M. 89 x 35 x 87 cm, 35 x 13,08 x 34,25”

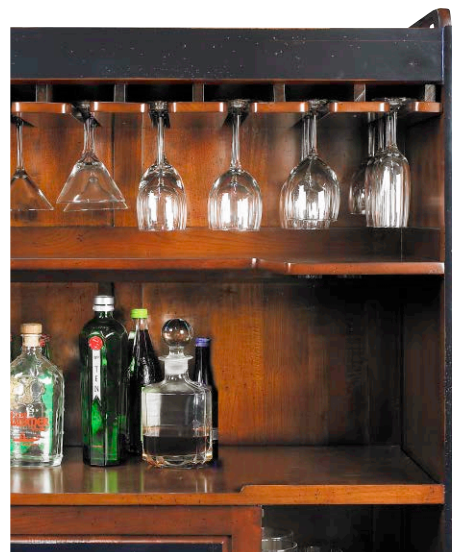

\* Interior impression of Casablanca bar

**Casablanca Bar, Black / MF047X**

M. 104x 52 x 110,50 cm, 40,90 x 20,50 x 43,50”

# Bar Trolley

Originally used by restaurants to deliver or display food and beverages, the Bar Trolley now provides you an easy way to serve your guests a delicious cocktail or a nice glass of wine.



Bar Trolley / MF163

# Polo Club Bar

Cosmopolitan fashion... Definitely slick, a bit laid back, still masculine like an aged trunk with its maple slats and brass hardware all around. For bons vivants with a sense of free-spirited style, best displayed in combination with prime imported wodka, Bombay Gin, Dutch Genever and Danish Aquavit. Ease of tools and available booze makes for a mean cocktail. For those with a life well lived and well traveled.



Polo Club Bar, Gunmetal Grey / MF114G

“Style matters!”



**Polo Club Bar, Gunmetal Grey / MF114G**

M. 55 x 60,50 x 98 cm, 21,65 x 23,80 x 38,60”



**Polo Club Bar, Black / MF114B**

M. 55 x 60,50 x 98 cm, 21,65 x 23,80 x 38,60”

# Grand Club Trunk Bar

Step off the beaten path and decide to create your own private club. The smell of leather, the feel of rich wood, the warm glow of subdued lighting. Act out that secret urge to be a bartender at Harry's Bar. Just wheel out this upscale serving station of superior drinks. Pull glasses from within, juggle bottles, break the ice and shake but do not stir.



Grand Club Trunk Bar / MF134



**Picnic Box Ceylon / MF161**

M. 60,00 x 25,00 x 103,50 cm, 25,00 x 7,30 x 43,10"

Focussing on the sociable side of travel, we've reinvented the classic Victorian trunk as a picnic hamper for drinks. Stock yours up and imagine yourself as a British aristocrat of old, entertaining dear friends in the countryside.



**Picnic Box Victoria / MF162**

M. 45 x 26 x 40 cm, 18,75 x 10,80 x 16,60"



**Grand Club Trunk Bar / MF134X**

M. 48 x 54 x 127 cm, 19 x 21,25 x 50"



**Six-in-One / FF101**

M. 22,75 x 34 x 22 cm, 8,95 x 13,40 x 8,65"



**Sommelier Put-Away / MF127**

M. 53 x 13 x 36 cm, 21 x 5,25 x 14,25"



**Butler's Tray / FF102**

M. 40,50 x 63,50 x 5 cm, 15,90 x 25 x 2"



**British Butler Table, French Finish / CF003F**

M. 47 x 59 x 56,50 cm, 34,25 x 26 x 24"



**Picnic Box Victoria / MF162**

Enjoy playing dice, chess or backgammon. An other option is to pull out the green board to play domino, poker or Monopoly. When not in the mood for games, just flip the board and go for cherry wood top or classic leather.



---

### Game Table / MF034

M. 120 x 120 x 45 cm, 47,20 x 24,60 x 17,70"

---

# Game Tables

A world of entertainment at your fingertips! Bring out the laughter, drama and drinks and go for check or broke. When not in the mood for games, flip the board and go for cherry wood top or classic leather. Park rule books and cartons on the lower level.



**Game Table, Black / MF020**  
M. 80 x 80 x 45 cm, 31,50 x 31,50 x 17,70"



Game Table / MF034

“The game  
is on!”



**Grandmaster's Box / MF112**  
M. 45 x 45 x 66 cm, 17,70 x 17,70 x 26"

# Trunk Tables

At the time of its invention, the Stateroom Trunk was a staple companion for wealthy Victorian travellers. Crafted from quality wood and adorned with sturdy brass fittings, it was much a work of art as a practical object. In today's world, it is an attractive focus piece which can be used for storage and, thanks to the addition of hand-turned legs, as a coffee table. For those who like to blend contemporary aesthetics with classic style...



**Stateroom End Table, Black / MF079B**

M. 45 x 53 x 56 cm, 17,70 x 20,90 x 22"



**Stateroom End Table, Petrol / MF079P**

M. 45 x 53 x 56 cm, 17,70 x 20,90 x 22"



\* Legs included

**Stateroom Trunk Table, Petrol / MF040P**

M. 82 x 58 x 46 cm, 32,30 x 22,80 x 18,10"



**Stateroom Trunk Table, Black / MF040B**

M. 82 x 58 x 46 cm, 32,30 x 22,80 x 18,10"



**Stateroom End Table, Black / MF079B**

Victorians called this style of table a cocktail table. The mariner's star brings to mind a First Class lounge. Exceptional artistry is used to apply the tabletop intarsia. Selected, contrasting veneers are expertly cut and assembled into a truly nautical table.



**Mariner Star Table / MF085**

M. 55 x 55 x 56 cm, 21,65 x 21,65 x 22"



**Bombay Box / MF111**

M. 40 x 56,50 x 65,50 cm, 15,70 x 22,20 x 26"



**Bombay Box, Honey / MF113**

M. 40 x 56,50 x 65,50 cm, 15,70 x 22,20 x 26"

The captain's desk was usually tailor made to offer maximum comfort and space in a minimal floor area. Drawers to house the crew's papers, sealed sailing instructions, logbooks, charts, instruments and a pair of flintlock pistols. Brass corners to protect from damage when being moved around. Sturdy construction, made of cherry and maple and leather insert top.



---

**Captain's Desk, Black / MF014**

M. 169,90 x 74,90 x 78 cm, 66,90 x 29,50 x 30,70"

---

You want something solid. Lived in and comfortable. Warm and rich looking. Soft and easy to the touch as if waxed and polished by generations of housemaids. Drawers to hold documents and treasures. Brass campaign corners to survive damage during challenging moves across the country or even oceans. Our furniture is made to travel well.



---

**Travel Desk 'Madras' / MF056**

M. 120 x 55 x 78 cm, 21,90 x 47,40 x 30,90"

---

“Let work be  
your hobby.”



**Navigator's Desk, Gunmetal Grey / MF022G**

M. 140,50 x 70 x 78 cm, 55,30 x 27,60 x 30,70”



**Navigator's Desk, Black / MF022**

M. 140,50 x 70 x 78 cm, 55,30 x 27,60 x 30,70”

Travelers and seafarers of yore had to be resourceful in order to survive. Desks on board ships had to be cleared and stowed at a moment's notice. Things had to be multi-functional. In the case of our desk, the two supports could act as steps into the navigator's bunk, or to mount a camel, whichever came first. The desktop, complete with drawers and brass bound, could act to stop musket bullets when under fire. Faux leather top, hand rubbed French finish, somewhat beat-up; proof of its many voyages and colorful history.



This desk is equipped with a folding table top to let it fit in any corner.  
Richly in black and honey. Drawers to hold documents and treasures.

---

**Toledo Desk / MF148**

M. 152 x 56,50 x 78,50 cm, 60 x 31 x 22,25" (with extension folded down M. 119,50 x 56,50 x 78,50 cm, 47 x 22,25 x 31")

---



High ranking officials have a duty to prepare reports from wherever they happen to be in the world. During the golden age of travel, when trips were personalised to the extent of bringing your own furniture, we envision a desk such as this, with its foldable legs, would have been indispensable to army officers and other public figures.

---

**Palmer Desk / MF158**

M. 150 x 45 x 82 cm, 62,50 x 18,75 x 34,20"

---

Florence Desk / MF157



In homage to the Victorian travellers who went to great lengths to attend to their correspondence while on the move, we've created this small fold-away desk. A charming piece that's handy in the home as it's small enough to fit almost anywhere and easy to pack up and store when not in use.



**Florence Desk / MF157**

M. 87 x 50 x 84,50 cm, 36,25 x 20,80 x 35,20"

Admirers of the travel trunks used by wealthy travelers will appreciate this administration-related take, in which we've created a 'pack-and go' desk with the same design features.



**Savannah Desk / MF156**

M. 90 x 50 x 81 cm, 37,50 x 20,80 x 33,75"

Filing cabinets are essentially boring entities. Choice-wise there's not much out there. Grandeur and elegance is not associated with the domain of organization. Stashing your files in a Hermès backpack or a vintage Louis Vuitton trunk, while certainly fancy, is not overly accessible. This cabinet is made to be handed down through generations.



---

**Campaign Files, Black / MF039**

M. 45 x 50 x 72 cm, 17,60 x 19,50 x 28,50"

---



Famous yachtsmen sailing from the USA were surprised at the lack of locker rooms, showers and docks when visiting the Royal Yacht Clubhouse at Cowes, England. Even a bar was absent while the cabins and staterooms of their visiting yachts were resplendent with grandeur. Our beautiful cabin cabinet with large porthole windows would probably have pleased them.

---

**Porthole Cabinet / MF027**

M. 46,50 x 92 x 153 cm, 18,30 x 36,10 x 60,10"

---



# Valet de Chambre

The 'Valet de Chambre' was traditionally a personal servant for the master of the house in Victorian times. It's hard to think of a more effective valet than our valet desk, which will never be tired and can't speak back. Easy to transform into a library unit or a living room support unit holding essentials.



Valet de Chambre / MF125

This desk holds some serious surprises and secrets so don't be fooled by its elegant appearance. Two stacked units offer campaign style compact storage. No wasted space here! At the same time you access a secret document box in the back. Big enough to store stacks of banknotes or someone's first love letters.



Secrétaire 'Grand Hotel' / MF063X

M. 49 x 80 x 108,50 cm, 19,30 x 31,50 x 42,70"



Valet de Chambre / MF125

M. 59 x 63,50 x 121,50 cm, 23,25 x 25 x 48"

AUTHENTIC  
NEW  
MODELS



---

**Canoe Bookshelf / MF243**

M. 78,70 x 52,10 x 228,60cm x 31 x 20,50 x 90"

---



Dory Bookshelf / Table With Glass / WO102

Our Dory can be used two ways; as a bookshelf, or as a glass topped table. Two oars, glass top and wooden stand. Use as table and fill inside with beach finds... upright... display your shells and books. Crackle finished wood.



---

**Dory Bookshelf / Table With Glass / WO102**

M. 49,50 x 40 x 119 cm x 19,50 x 15,70 x 46,90"

---

# Gigs

Gigs were invaluable when in port or moored outside. Referred to as rowboats by land-bound folk, a gig was easy to lower overboard, needed minimum crew, and was quick to dispatch. When stowed, it nested in the long boat or pilot boat secured in the center of the main deck. Our lapstrake (overlapping strips of wood) gigs are not seaworthy, but they most certainly look like it! Clinker build, they add flair and atmosphere to any room, and display shelves turn them into fun cabinets and bookcases.



**Bosun's Gig/ MF036**  
M. 68 x 30,50 x 185 cm, 26,80 x 12 x 72,80"



**Bosun's Gig, White / MF036W**  
M. 68 x 30,50 x 185 cm, 26,80 x 12 x 72,80"



**Library Step-up / MF155**

M. 45 x 50 x 123 cm x 17,75 x 19,50 x 48,50"



**Library Ladder, Gunmetal Grey / MF068G**

M. 45 x 50 x 245 cm x 17,70 x 19,70 x 97"



**Butler's Buddy / MF140G**

# Butler's Buddy

The Butler's Buddy is designed for men who like fashion and take care of their gear. Made for looks but also practicality. That's why women want their own too.



**Butler's Buddy / MF140G**

M. 51,50 x 47 x 104 cm, 20,26 x 18,50 x 41"



\* No hangers included

**Grand Hotel Rack / MF132**

128,50 x 56 x 165 cm, 50,55 x 22 x 65"

# Travel Cabinets

Inspired by early 19th C. travel cabinets, Authentic Models offers a highly practical trunk reproduction called the Armoire. It features shelves and drawers to store and display. Hand-sewn bridle leather straps and brass hardware support a foldout shelf for use as workspace. Inset shelf-unit with a removable mirror stored in the back. Fun, decorative and practical. Locks with keys.



**Stateroom Armoire, Black / MF077B**

M. 60 x 50 x 130 cm, 19,70 x 23,60 x 51,20"

Wealthy Victorians didn't pack light when travelling by luxury steamer! They therefore created beautiful wheeled trunks to bring clothing and other possessions on board. In a new functional twist, we've turned our replica trunks into chests of drawers. So you can bring a taste of the luxury steamer lifestyle into your home via a stylish storage solution.



---

**Stateroom Drawers Large / MF159**

M. 53 x 45 x 1,14 cm, 22 x 18,75 x 34,50"

---



---

**Stateroom Drawers Small / MF160**

M. 53 x 45 x 65,50 cm, 22 x 18,75 x 27,30"

---



# Campaign Stacking Units



In the rich tradition of 19th C. furniture makers who supplied furniture to all corners of the Empire, Authentic Models has developed a system of stackable units that can be filled and used in different ways. Units can be arranged in single stacks, or to fill an entire wall. They can section off one part of a room, as both front and back are finished. Always practical, decorative and never boring.

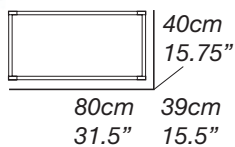

**Campaign Stacking Unit, Open / MF201**  
M. 80 x 39 x 40 cm, 31,50 x 15,40 x 15,70"

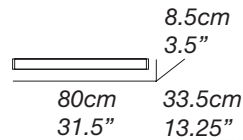

**Campaign Stacking Unit, Base / MF200**  
M. 80 x 33,50 x 8,50 cm, 31,50 x 13,20 x 3,30"



16cm  
6.5"  
37.5cm 31.5cm  
14.75" 12.5"

**Campaign Stacking Unit, Tray / MF205**

M. 37,50 x 31,50 x 16 cm, 14,80 x 12,40 x 6,30"

28cm  
11"  
80cm 39cm  
31.5" 15.5"



**Campaign Stacking Unit, Small / MF206**

M. 80 x 39 x 28 cm, 31,50 x 15,40 x 11"



40cm  
15.75"  
80cm 39cm  
31.5" 15.5"

**Campaign Stacking Unit, Doors / MF202**

M. 80 x 39 x 40 cm, 31,50 x 15,40 x 15,70"

40cm  
15.75"  
80cm 35cm  
31.5" 14"



**Campaign Stacking Unit, Desk / MF207**

M. 80 x 39 x 43,40 cm, 31,50 x 13,80 x 17,10"



12cm  
4.75"  
76cm 33cm  
30" 13"

**Campaign Stacking Unit, Drawers / MF204**

M. 76 x 33 x 12 cm, 29,90 x 13 x 4,70"

2.5cm  
1"  
76cm 32.5cm  
30" 13"



**Campaign Stacking Unit, Shelf / MF203**

M. 76 x 32,50 x 2,50 cm, 29,90 x 12,80 x 1"

# Travel Trunks

Victorian travel trunks are the inspiration behind these freestanding shelf units we've created for books and other objects. A perfect complement to our many travel-related items. Available as a modular set or as individual pieces.

Endless Regency Large, Honey Interior / MF219

Endless Regency Medium, Black Interior / MF215

Endless Regency Small, Black Interior / MF214

---

**Endless Regency Medium, Black Interior / MF215**

M. 40 x 35,50 x 85,50 cm, 16,60 x 14,80 x 33,75"

---



---

**Endless Regency Small, Black Interior / MF214**

M. 40 x 35,50 x 43,50 cm, 16,60 x 14,80 x 18,10"

---

---

**Endless Regency Large, Black Interior / MF216**

M. 40 x 35,50 x 123,50 cm, 16,60 x 14,80 x 49,50"

---

---

**Endless Regency Medium, Honey Interior / MF218**

M. 40 x 35,50 x 85,50 cm, 16,60 x 14,80 x 33,75"

---



---

**Endless Regency Small, Honey Interior / MF217**

M. 40 x 35,50 x 43,50 cm, 16,60 x 14,80 x 18,10"

---

---

**Endless Regency Large, Honey Interior / MF219**

M. 40 x 35,50 x 123,50 cm, 16,60 x 14,80 x 49,50"

---



**Endless Regency 4 Honey Interior / MF230**  
**Insert box 1 Wine Rack Honey / MF233**  
**Insert box 3 Box Honey / MF237**

# Endless Regency Collection



The original Handbook for Travelers in India, Burma and Ceylon, carries extensive instructions for the minimum amount of items needed for an extensive voyage in the tropics. Boxes, trunks and chests were packed and hauled on exploration, hunting, or military expeditions that traversed mountains and deserts.

All this had to be packed and unpacked every single day. The design and manufacture of furniture fitting all these conditions and ways of travel was both an art and a science. In the rich tradition of traditional furniture makers who supplied furniture to all corners of the globe, Authentic Models has developed an Endless Regency Collection that can be combined with different inserts and create endless possibilities to mix and match.

They can section off one part of a room, as both front and back are finished. Always practical, decorative and never boring. Exquisitely finished, made from solid mahogany and maple finished in medium honey and black, these brass bound units will survive centuries and fill both grown-up and kid's spaces in any way needed.



“Endless  
Mix and Match.”



Our Endless Regency Insert boxes are definitely multi-functional. Collectors want a travel trunk that stores and appeals in its own right. Housekeepers want space and functionality. Enjoy its many drawers and fun pull-out shelves. Solid, heavy, bronze campaign pulls. Elegant and practical.



“Boxes to hold  
documents and  
treasures.”



AUTHENTIC  
NEW  
MODELS



**Endless Regency 4 Black Interior / MF229**  
M. 77 x 36 x 82 cm, 30,30 x 14,15 x 32,30"

AUTHENTIC  
NEW  
MODELS



**Endless Regency 4 Honey Interior / MF230**  
M. 77 x 36 x 82 cm, 30,30 x 14,15 x 32,30"

AUTHENTIC  
NEW  
MODELS



**Endless Regency 6 Black Interior / MF231**  
M. 77 x 36 x 12 cm, 30,30 x 14,15 x 47,65"

AUTHENTIC  
NEW  
MODELS



**Endless Regency 6 Honey Interior / MF232**  
M. 77 x 36 x 121 cm, 30,30 x 14,15 x 47,65"

AUTHENTIC  
NEW  
MODELS



# Inserts Medium Honey

---

## Insert box 1 Wine Rack Honey / MF233

M. 34 x 34 x 36 cm, 13,40 x 13,40 x 14,15"

---

AUTHENTIC  
NEW  
MODELS



---

## Insert box 2 Name Tag 3 Honey / MF235

M. 34 x 34 x 36 cm, 13,40 x 13,40 x 14,15"

---

AUTHENTIC  
NEW  
MODELS



---

## Insert box 3 Box Honey / MF237

M. 34 x 34 x 36 cm, 13,40 x 13,40 x 14,15"

---

AUTHENTIC  
NEW  
MODELS



---

## Insert box 4 Open 3 Honey / MF239

M. 34 x 34 x 36 cm, 13,40 x 13,40 x 14,15"

---

AUTHENTIC  
NEW  
MODELS



---

## Insert box 5 Sunken 3 Honey / MF241

M. 34 x 34 x 36 cm, 13,40 x 13,40 x 14,15"

---

# Inserts Black



**Insert box 1 Wine Rack Black / MF234**

M. 34 x 34 x 36 cm, 13,40 x 13,40 x 14,15"



**Insert box 2 Name Tag 3 Black / MF236**

M. 34 x 34 x 36 cm, 13,40 x 13,40 x 14,15"



**Insert box 3 Box Black / MF238**

M. 34 x 34 x 36 cm, 13,40 x 13,40 x 14,15"



**Insert box 4 Open 3 Black / MF240**

M. 34 x 34 x 36 cm, 13,40 x 13,40 x 14,15"



**Insert box 5 Sunken 3 Black / MF242**

M. 34 x 34 x 36 cm, 13,40 x 13,40 x 14,15"

You just walked the Rue Faubourg and are about to descend into the Louvre. Now's the time to make a pit stop in a reputable brasserie, maybe the Bofinger near the Opera? You are counting on a delicious café, maybe a small liqueur... but you can only hope you'll find an empty barstool to rest your weary feet. Elbow on the bar rail, comfortably parked, with feet resting on the ring encircling the stool legs...



**Barstool 'Grand Hotel', Honey / MF043A**  
M. 37,50 x 37,50 x 73 cm, 14,80 x 14,80 x 28,70"

Its shape goes back a hundred years; its mystique is that of early 1900's offices. It can survive a student's dorm room and will faithfully and decorously serve as dining chair.



\*Includes blank hardware plaque for personalisation

**Navy Chair, Black/Honey / MF046Z**  
M. 55 x 60 x 79 cm, 21,70 x 23,60 x 38,20"

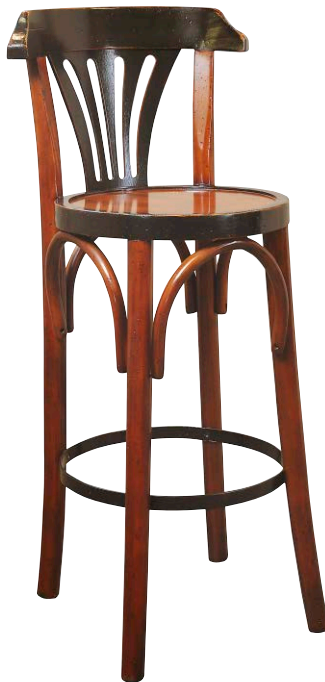

**Barstool De Luxe 'Grand Hotel', Honey / MF044A**  
M. 37,50 x 37,50 x 101,50 cm, 14,80 x 14,80 x 40"



\*Includes blank hardware plaque for personalisation

**Navy Chair, Black / MF046B**  
M. 55 x 60 x 79 cm, 23,60 x 21,60 x 30,70"



Barstool 'Grand Hotel', Honey / MF043A



AUTHENTIC  
NEW  
MODELS

Mayan High Barstool, Black / MF172

M. 38 x 38 x 76 cm, 15 x 15 x 30"



AUTHENTIC  
NEW  
MODELS

Mayan Low Barstool, Black / MF174

M. 34 x 34 x 46 cm, 13 x 13 x 18"



AUTHENTIC  
NEW  
MODELS

Mayan Bench Stool, Black / MF176

M. 150 x 34 x 46 cm, 59 x 13 x 18"

Striking, yet unassuming, our Purser's Chair is the answer to many requests for a desk chair to match our collection of desks. Handmade in hardwood, this chair will survive the ages when treated with respect.



\*Includes blank hardware plaque for personalisation

**Purser's Chair, Black / MF081B**  
M. 55 x 61 x 78,50 cm, 23,60 x 21,60 x 30,70"



\*Includes blank hardware plaque for personalisation

**Purser's Chair, Black & Honey / MF081**  
M. 55 x 61 x 78,50 cm, 23,60 x 21,60 x 30,70"



\*Includes blank hardware plaque for personalisation

**Purser's Chair, Gunmetal Grey & Honey / MF081G**  
M. 55 x 61 x 78,50 cm, 23,60 x 21,60 x 30,70"



**Fireside Stool / MF115**  
M. 52 x 40 x 60,50 cm, 20,50 x 15,75 x 23,75"

# Campaign Chair

Originally designed by London Army & Navy purveyors for Imperial Army officers on the move. Legs and frame rolled up inside the canvas seat or leather. Then in the 1920's taken by European settlers of the Argentina pampas, it became the gaucho's stock fo trade. Aged ones now populate living rooms of haciendas in Argentina and Uruguay. Designed to function on uneven footing, their flexibility surprises.



Bridle Leather  
Campaign Chair / MF122



**Bridle Leather Campaign Chair / MF122**

M. 55 x 56 x 89 cm x 21,75 x 22 x 35"

WE ARE PROUD  
TO PRESENT YOU...



## **ACE** Collection

Inspired by the pioneering creativity behind the historic objects we famously breathe new life into, Authentic Models is proud to introduce a brand new collection of completely original, high-end furniture and décor. The ACE Collection looks to the future by learning from the past, grounding contemporary design in the painstaking attention to detail associated with traditional craftsmanship.

The result is unexpected, daring, yet superbly elegant pieces with truly timeless appeal, conceived to resonate with adventurous spirits who crave uncompromised quality and originality.

True to Authentic Models' roots in travel and exploration, the very first ACE Collection furniture celebrates the nautical lifestyle with console and side tables inspired by porthole construction. Available in walnut, gold and gold leaf finishing, these come in three sizes which can be purchased individually or as a set.

These intriguing new items are just the start of an exciting new adventure in meaningful, high-end aesthetics. Watch out for more new introductions throughout the year!



“Style is an attitude.”



Walnut



Gold



Gold Leaf



AUTHENTIC  
NEW  
MODELS



**ACE Console Walnut / MF167**

M. 120 x 46 x 75 cm, 47 x 18 x 30"

AUTHENTIC  
NEW  
MODELS



**ACE Console Gold / MF166**

M. 120 x 46 x 75 cm, 47 x 18 x 30"

AUTHENTIC  
NEW  
MODELS



**ACE Console Gold Leaf / MF166GL**

M. 120 x 46 x 75 cm, 47 x 18 x 30"

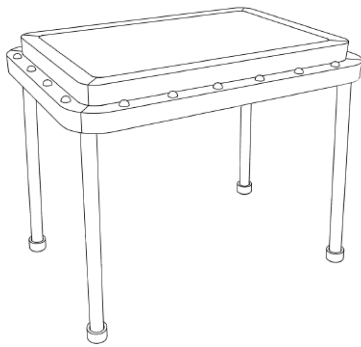

**ACE Side Table M Walnut / MF169**

M. 60 x 40 x 45 cm, 24 x 16 x 18"

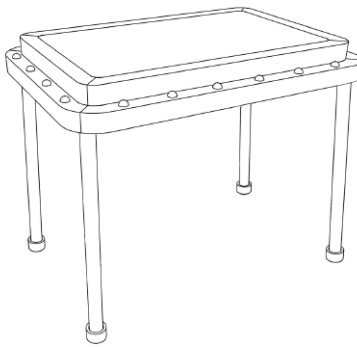

**ACE Side Table M Gold / MF168**

M. 60 x 40 x 45 cm, 24 x 16 x 18"

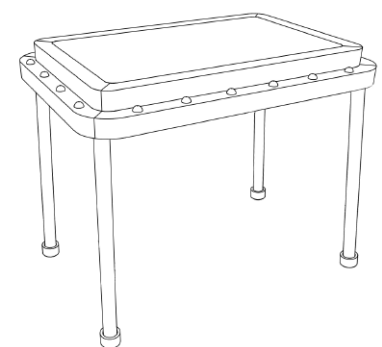

**ACE Side Table M Gold Leaf / MF168GL**

M. 60 x 40 x 45 cm, 24 x 16 x 18"

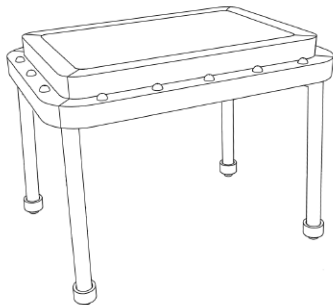

**ACE Side Table S, Walnut / MF171**

M. 50 x 35 x 33 cm, 20 x 14 x 14"

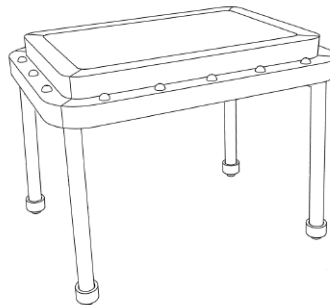

**ACE Side Table S, Gold / MF170**

M. 50 x 35 x 33 cm, 20 x 14 x 14"

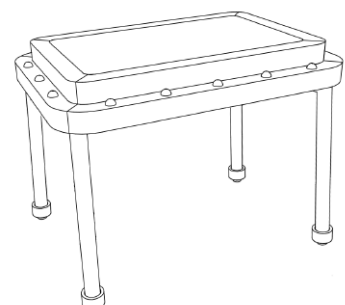

**ACE Side Table S, Gold Leaf / MF170GL**

M. 50 x 35 x 33 cm, 20 x 14 x 14"



# AVIATION

From leisurely balloon rides to practical passenger jets and battle-winning war planes, conquering the skies remains one of mankind's greatest achievements. Whether the triumph of flight signifies glamorous worlds of adventure and exploration or defending your nation's freedom, Authentic Models celebrates its numerous forms through beautifully handcrafted original decoration pieces.



# Supersonic Passenger Plane

The Concorde was a supersonic passenger plane. Only twenty aircraft have been built, including four prototypes. The plane flew for the first time in 1969, it made its last flight on October 24, 2003.



“Ready for  
take-off.”



\* Cockpit can be tilted

---

**Concorde / AP460**

M. 86 x 38 x 46 cm, 33,85 x 14,95 x 18,10" Stand included

---

“Elegant  
and agile.”



Spitfire / AP456

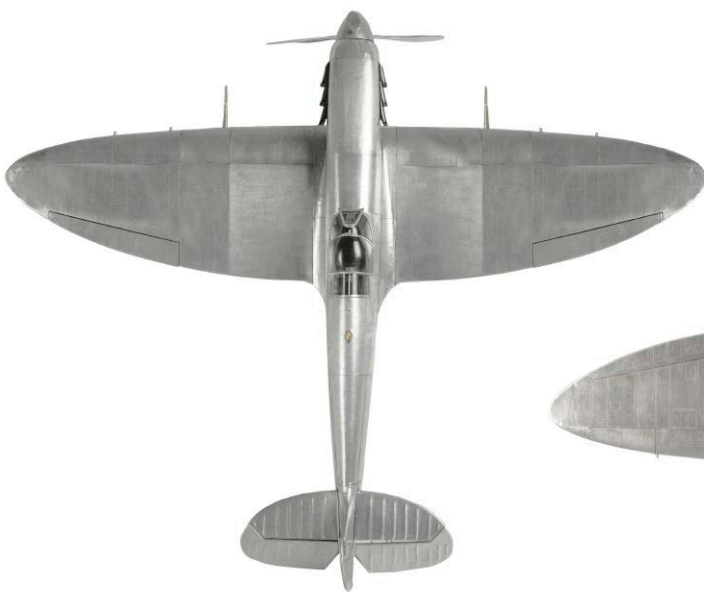

Stand included

**Spitfire / AP456**

M. 60,50 x 75,50 x 17 cm, 24 x 29,75 x 6,75”

The legendary Spitfire fighter was introduced in 1936 as a short-range, high-performance and single-seat aircraft. Beloved by pilots it still has an iconic status. Our model has unbelievable details like retractable main wheels, sliding cockpit window and functioning tail rudder. Shipped with an aluminum stand with plaque.



- fully detailed cockpit
- includes plaque on stand
- flat metal sheet attached to lightweight frame
- functioning ailerons and tail rudder



Sleek and powerful, Constellations set a number of speed and distance records, despite experiencing frequent motor problems which led to them being jokingly called the most reliable three engine aircraft. The plane's elegant appearance was the result of no two bulkheads being the same shape. A design which has long since been superseded by cheaper, more pressure-change-resistant tube constructions.



Stand included

---

**Constellation / AP458**

M. 70 x 75 x 13 cm, 27,50 x 29,50 x 5,10"

---



Constellation / AP458



The P-51 Mustang was the first US built fighter in action after the fall of France, successfully engaging every air-born opponent. Fast, powerful, and manoeuvrable, with 75-gallon tanks under each wing, its ability to fly 6-hour missions was unheard of at the time.

WWII Mustang / AP459



- metal sheet covering, attached to lightweight frame
- fully detailed cockpit, sliding cockpit cover
- retractable main wheels
- includes plaque on stand



Stand included

### WWII Mustang / AP459

M. 66 x 75 x 25 cm, 26 x 29,50 x 10"



# A unique mark in history

Only 199 Trimotors were ever built. Today, just 8 remain airworthy. Yet this quirky aircraft, with its externally mounted engine gauges which pilots could only check by looking out of the window, left unique marks in history. In 1929, the Trimotor was the first plane to fly over the South Pole. And in 1932 Franklin Roosevelt flew in one during his 1932 presidential campaign, in one of first uses of aircraft in an election.

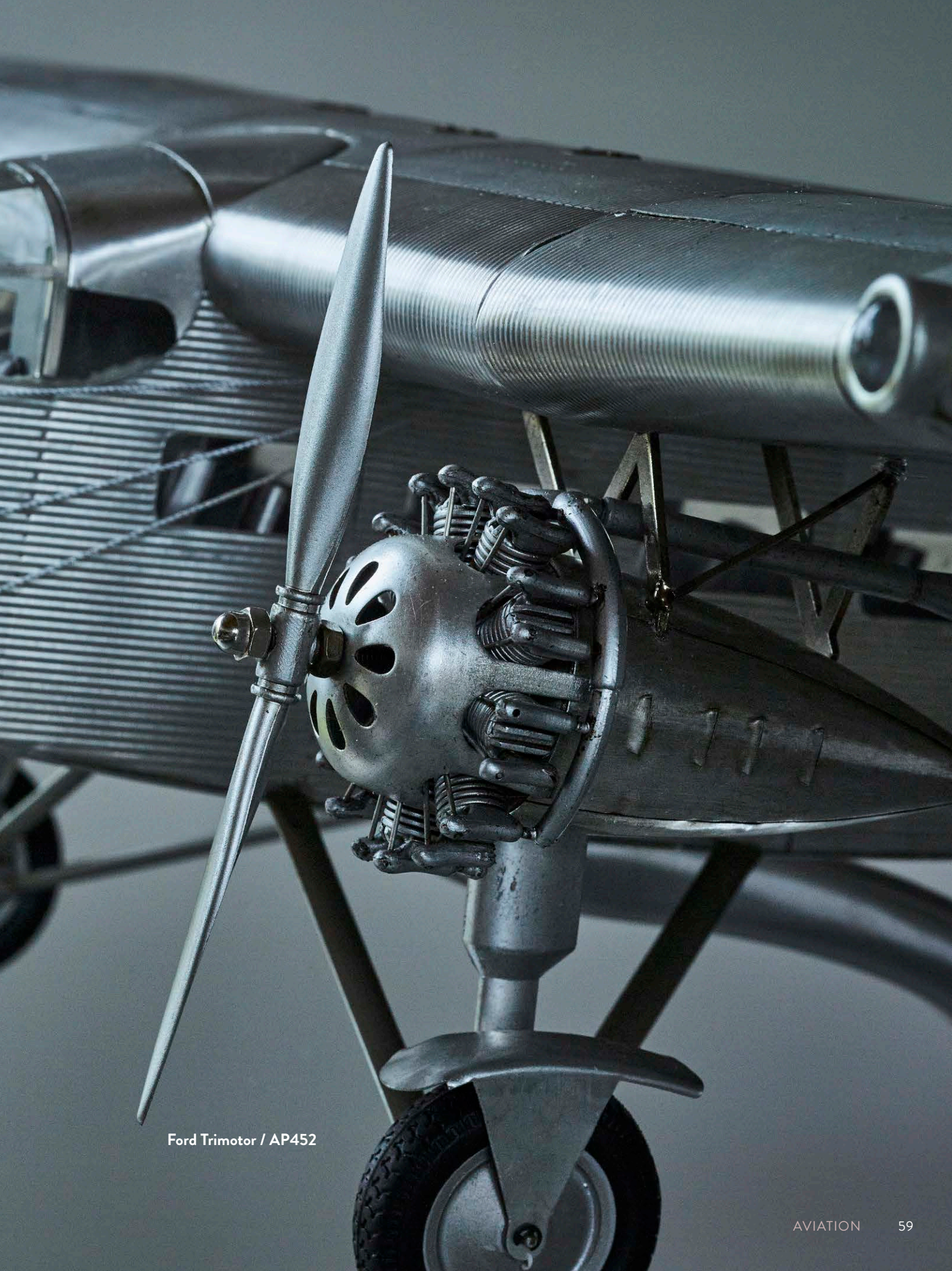

Ford Trimotor / AP452



Stand included

---

**Ford Trimotor / AP452**

M. 67 x 102 x 20 cm, 26,40 x 40,20 x 7,90"

---



Stand included

---

**Dakota DC-3 / AP455**

M. 64,50 x 97 x 17 cm, 25,60 x 38,60 x 6,70"

---



# Record Breakers

The DC3 has earned the epithet “Workhorse of the Skies”. Thousands were produced from the end of WWII into the 1950s by the Douglas Aircraft works. Military, civilian, government, private, you name it. Utterly reliable. Even now it’s possible to find them flying from remote airports, landing on the tightest strips. Legendary and nostalgic. Aluminum, riveted propellers, noisy, but also safe and familiar.

# “Early travel agent advertising sign.”



**On Top Of The World / AP108**  
M. 22 x 26,50 x 31 cm, 8,70 x 10,40 x 12,20”



**Autour Du Monde / AP103A**  
M. 21 x 26,50 x 18 cm, 8,30 x 10,40 x 7,10”

The iconic aluminum Mustang is an exact copy of WWII original trench art models.



**WWII Mustang Desk Model / AP098**  
M. 15 x 16 x 16 cm, 6 x 6,50 x 6,50”

This iconic aluminum Spitfire is an exact copy of a WWII original trench art model. The original was probably crafted by a plane mechanic, stationed on an isolated British airfield.



**Spitfire Travel Model / AP099**  
M. 19 x 20 x 14,50 cm, 7,50 x 8 x 5,75”

The Corsair fighter aircraft is an excellent reminder of how collaborative perseverance wins the day. This American plane initially had difficulties landing on aircraft carriers, the deployment it was designed for.



---

**Corsair Paperweight / AP102**  
M. 17,50 x 17 x 15 cm, 6,90 x 6,70 x 5,90"

---

Nostalgic and perfect replica of an early travel agent advertising sign.



---

**Desktop DC-3 / AP105**  
M. 27 x 36 x 17,50 cm, 10,60 x 14,20 x 6,90"

---

The DC3 has earned the epithet "Workhorse of the Skies". Thousands were produced from the end of WWII into the 1950s by the Douglas Aircraft works. Military, civilian, government, private, you name it.



---

**1930s DC-3 / AP110**  
M. 50 x 51 x 30 cm, 19,70 x 20,30 x 11,80"

---

London-New York in 3 hours: the only supersonic passenger aircraft ever made. Recreated from original models displayed at the top travel agents.



---

**Concorde / AP112**  
M. 46 x 17,50 x 21,25 cm, 18,10 x 6,90 x 8,30"

---



# Experienced Pilots

Most definitely it's the size. It's BIG. Built with an interesting array of materials. Lightweight frame stretched with fabric. Down to the smallest detail a replica of the original, which was actually only 5.7m long (less than 19 ft.) to begin with. Built by the thousands during the Great War, in many colors and configurations. Our model fits large spaces as well as large personalities (of which there is no shortage in this world!). Pair it with propellers, old maps, a pilot's desk.

The Sopwith was the mainstay fighter-plane of the British and USA air forces in the early 1900s. Brightly painted in various national colors, it ruled the skies for a number of years.



---

**Spad, transparent / AP413T**  
M. 60 x 76 x 23 cm, 23,60 x 29,90 x 9,10"

---

A lightweight frame is assembled and silk fabric is stretched across, similar to the original construction in the early 1900s.



---

**Sopwith Camel, transparent / AP502T**  
M. 102 x 150 x 45,50 cm, 40,20 x 59,10 x 17,90"

**Sopwith Camel, transparent 250cm Wingspan / AP602T**  
M. 167 x 250 x 71 cm, 65,70 x 98,40 x 28"

---

As WWI progressed, every opportunity to gain advantage had to be taken. Fighter plane engine capacity was increasing. But that was worthless unless propellers were also modified to turn that extra power into more speed. While the classic 2-blade propeller was known to be the most efficient design, lengthening the blades to utilize the increased power would result in them touching the ground during take-off and landing. One solution was the introduction of the four-blade propeller.



**Four Blade Wooden Propeller / AP139**

M. 120 x 120 x 5,10 cm, 47,20 x 47,20 x 2"



**Small Propeller, 4 Blade / AP142**

M. 70 x 70 x 5cm, 27,60 x 27,60 x 2"



You can't see the mechanic from your open cockpit. You yell..."Contact" and the propeller jumps to life, the plane starts to shudder. The mechanic pulls away the wheel blocks and escapes. The noise is incredible, a nine-cylinder Hispano-Suiza...spewing clouds of vaporized castor-oil. Complete cacophony. The propeller is by now an invisible whirr. Out of the way, this is hands-on flight at its finest. Ready for take-off?

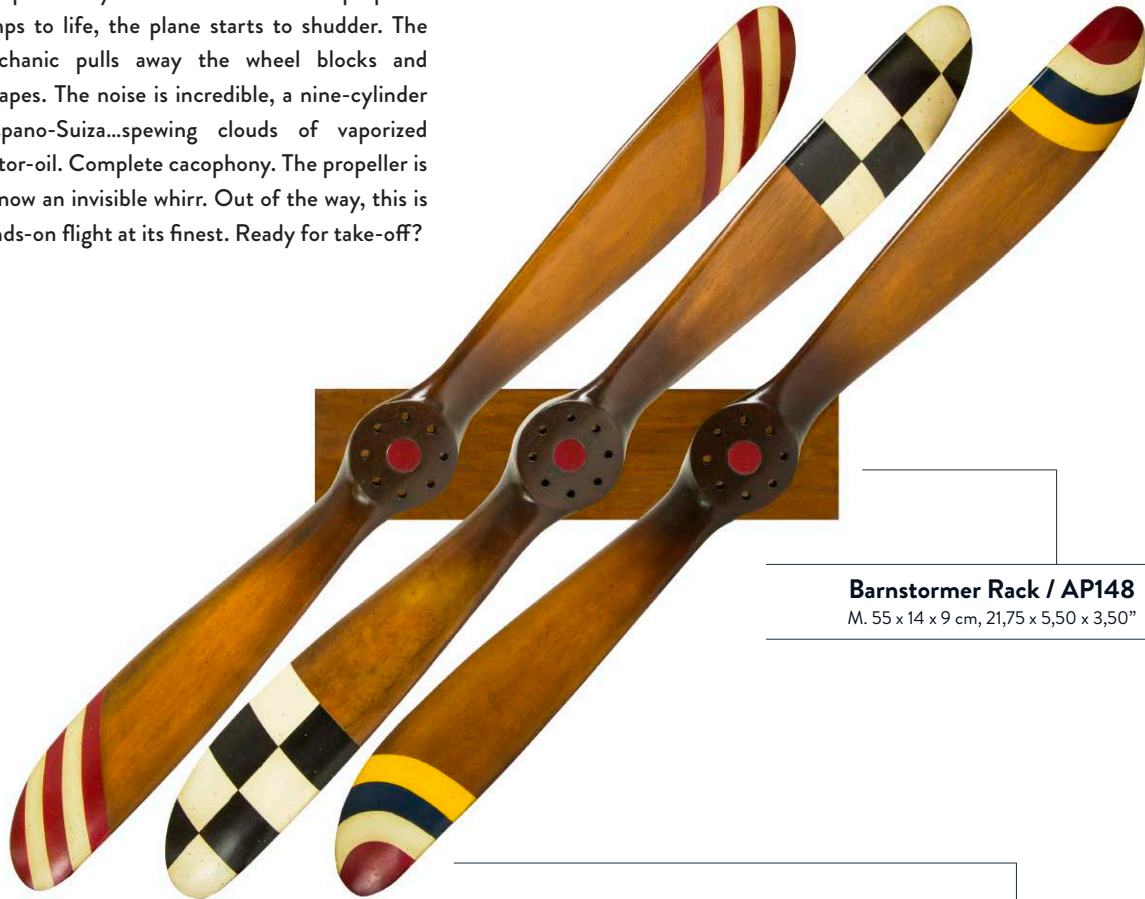

**Barnstormer Rack / AP148**

M. 55 x 14 x 9 cm, 21,75 x 5,50 x 3,50"

**Barnstormer # 1 / AP145**

M. 120 x 13,50 x 6,50 cm, 47,25 x 4 x 2,50"

**Barnstormer # 3 / AP147**

M. 120 x 13,50 x 6,50 cm, 47,25 x 4 x 2,50"

**Barnstormer # 2 / AP146**

M. 120 x 13,50 x 6,50 cm, 47,25 x 4 x 2,50"



**Small Propeller, Red/Gold / AP143**

M. 70 x 8 x 4,50 cm, 27,50 x 3,25 x 1,75"



**Small Propeller, Black/Ivory / AP144**

M. 70 x 8 x 4,50 cm, 27,50 x 3,25 x 1,75"

# PROPELLERS

## 120 CM / 47.25"



**Sopwith Red Stripes, Small / AP176**

M. 120 x 12 x 5,80 cm, 47,25 x 4,75 x 2,30"



**Sopwith Propeller, Silver / AP149S**

M. 120 x 13,50 x 6,50 cm, 47,25 x 5,50 x 2,75"



**Sopwith Propeller, Small / AP149**

M. 120 x 13,50 x 6,50 cm, 47,25 x 5,50 x 2,75"



**Sopwith WWII, Small / AP178**

M. 120 x 12 x 5,80 cm, 47,25 x 4,75 x 2,30"



**Sopwith Star, Small / AP184**

M. 120 x 12 x 5,80 cm, 47,25 x 4,75 x 2,30"



# PROPELLERS

## 120 CM / 47.25"

Nothing symbolises aviation history more simply and evocatively than propellers. We've created faithful replicas of classic models and decorated them to become attractive wall décor. Respecting and celebrating history while making it relevant to modern day interiors.



**WWI Wood Propeller, Small / AP150**

M. 120 x 10,50 x 6 cm, 47,25 x 5,50 x 2,75"



**WWI Vintage Propeller, Small / AP150F**

M. 120 x 10,50 x 6 cm, 47,25 x 5,50 x 2,75"



**WWI Vintage Star, Small / AP177**

M. 120 x 12 x 5,80 cm, 47,25 x 4,75 x 2,30"



**WWI Blue tip, Small / AP186**

M. 120 x 12 x 5,80 cm, 47,25 x 4,75 x 2,30"

# PROPELLERS

## 186 CM / 73.2"

Wood propellers used to be replaced as often as tires. Old ones were usually taken home, completed with a clock, and hung over the mantel. Mechanics, pilots, flight-crew. They wore propeller tiepins and badges and transformed propellers into memorabilia. A continuation of a flight-tradition...



**WWI Vintage, Large / AP155F**  
M. 186 x 15 x 9 cm, 73,20 x 5,90 x 3,50"



**Vintage Flight / AP158**  
M. 186 x 15 x 9 cm, 73,20 x 5,90 x 3,50"



**Vintage Black Tips, Large / AP182**  
M. 186 x 15 x 9 cm, 73,20 x 5,90 x 3,50"

# PROPELLERS

186 CM / 73.2"



**WWI Wood Propeller / AP155**  
M. 186 x 15 x 9 cm, 73,20 x 5,90 x 3,50"



**WWI Blue tip, Large / AP185**  
M. 186 x 15 x 9 cm, 73,20 x 5,90 x 3,50"

AUTHENTIC  
NEW  
MODELS



**WWI Vintage Star, Large / AP180**  
M. 186 x 15 x 9 cm, 73,20 x 5,90 x 3,50"

# PROPELLERS

186 CM / 73.2"

AUTHENTIC  
NEW  
MODELS



**Sopwith Star, L / AP183**  
M. 186 x 15 x 9 cm, 73,20 x 5,90 x 3,50"



**Sopwith WWII, L / AP181**  
M. 186 x 15 x 9 cm, 73,20 x 5,90 x 3,50"



**Sopwith Red Stripes, L / AP179**  
M. 186 x 15 x 9 cm, 73,20 x 5,90 x 3,50"



**Sopwith Propeller L / AP159**  
M. 186 x 15 x 9 cm, 73,20 x 5,90 x 3,50"

Stainless steel wires and nylon line keep planes in constant graceful motion. Fun interior décor, kid's room and den, will survive the ages, out of reach...

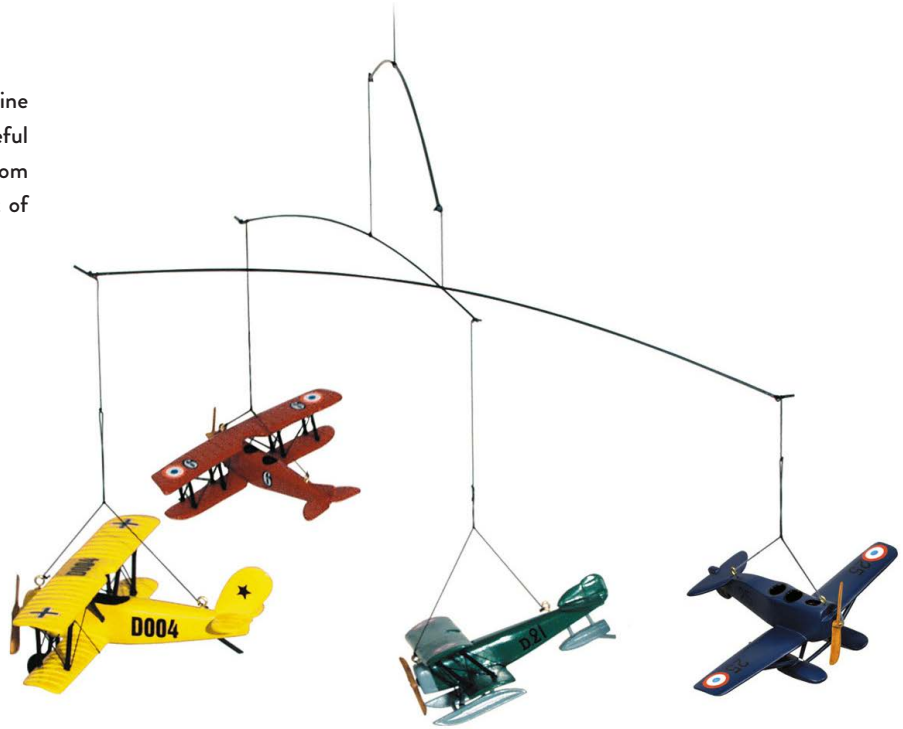

---

**Flight Mobile, 1920 / AP120**

M. 66 x 58,50 x 30,50 cm, 26 x 23 x 12"

---

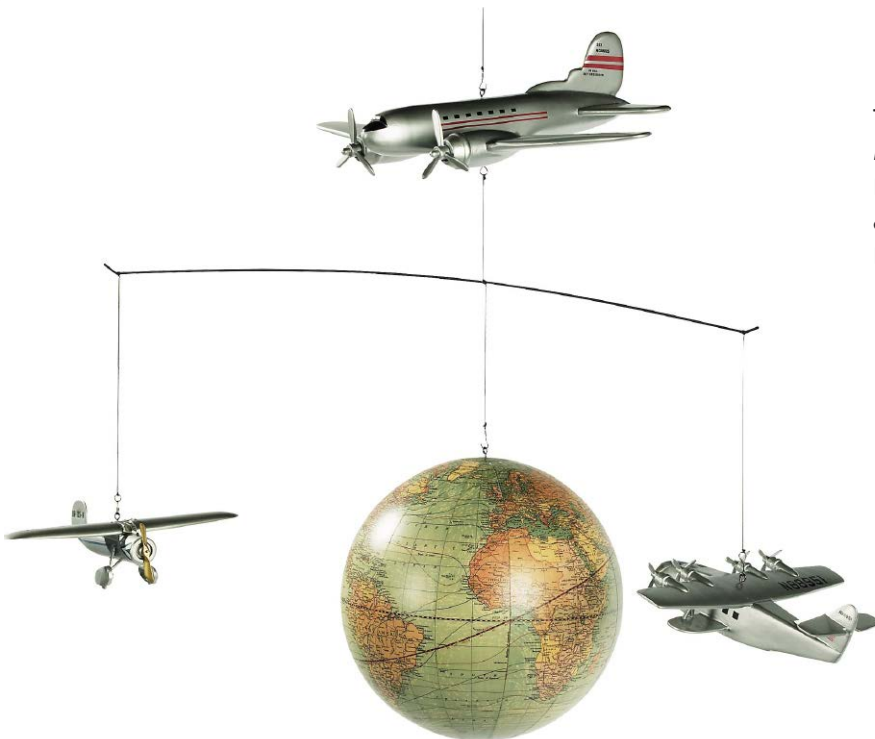

Three wooden planes; Lockheed Winnie Mae, Pan Am China Clipper, and the Douglas DC3 all gracefully glide around our 1920s globe, all hand applied gores. Easy assembly.

---

**Around The World Mobile x / AP124**

M. 34,50 x 66 x 40 cm, 13,60 x 26 x 15,70"

---



“A Zen-like mood,  
soon kicks in.”

Iconic and inspiring helium filled balloons were one of aviation's first successes. Since 1783, balloons have traveled the skies. Our largest model to date comes complete with a rattan basket hanging from hand-knotted netting and wood toggles. The large balloon carries sand bags at the ready for release as ballast.



# Balloon Mobiles

Five little balloons peacefully turning around each other. Rainbow colors, pastels or black and white all hand made, easy to assemble.



**Flying the Skies Mobile, Black & White / AP133**

M. 85 x 8,80 x 66,50 cm, 33,50 x 3,50 x 26,25"



**Flying the Skies Mobile, Pastel Rainbow / AP132**

M. 85 x 8,80 x 66,50 cm, 33,50 x 3,50 x 26,25"

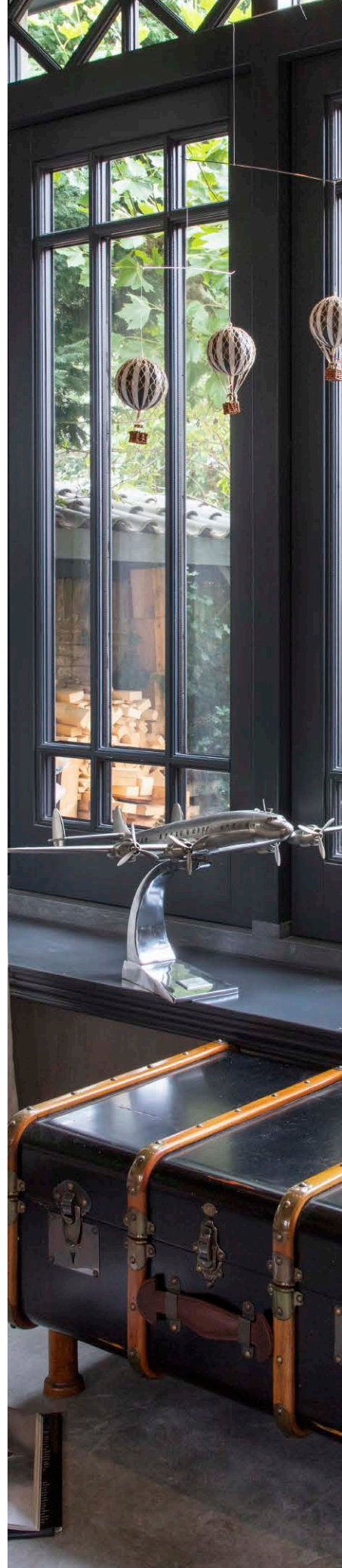



**Flying the Skies Mobile, Primary / AP128**

M. 85 x 8,80 x 66,50 cm, 33,50 x 3,50 x 26,25"



**Flying the Skies Mobile, Pastel / AP129**

M. 85 x 8,80 x 66,50 cm, 33,50 x 3,50 x 26,25"



# Special Occasions

Balloons combine color, décor and themes, all-in-one. They're as fascinating today as they were a century ago. Imagine viewing the earth from above, free as a bird, holding onto a balloon basket. Ideal present for special Holidays like 4th of July, Valentines Day or to celebrate a birthday.

AUTHENTIC  
NEW  
MODELS



---

**USA**  
AP160US / AP161US / AP163US

---

AUTHENTIC  
NEW  
MODELS



---

**Red Hearts**  
AP160RH / AP161RH / AP163RH

---

AUTHENTIC  
NEW  
MODELS



---

**Blue Stars**  
AP160BS / AP161BS / AP163BS

---

# Squares and Double Lines



**Check Red**  
AP160CR / AP161CR / AP163CR

**Check Blue**  
AP160CB / AP161CB / AP163CB



**Blue Double**  
AP160DB / AP161DB / AP161DB

**Green Double**  
AP160GD / AP161GD / AP163GD



**Yellow Double**  
AP160DY / AP161DY / AP161DY

**Red Double**  
AP160DR / AP161DR / AP161DR≠



# The Originals



Rainbow Pastel



Mint



Rainbow



True Red



Blue



True Green



True Yellow



White Ivory



Lavender



Black



Pink

# New Designs



Blue Double



Green Double



Yellow Double



Red Double



Check Blue



Check Red



Blue Stars



Red Hearts



USA



\*Gift Package AP160



### Floating The Skies / AP160\*

Ø 13 x 8,50 cm, Ø 5,30 x 3,30"

AP160D Blue  
 AP160E Rainbow  
 AP160F Rainbow Pastel  
 AP160G True Green  
 AP160K Black  
 AP160L Lavender  
 AP160M Mint  
 AP160P Pink  
 AP160R True Red  
 AP160W White/Ivory  
 AP160Y True Yellow  
 AP160DB Blue Double  
 AP160DG Green Double  
 AP160DY Yellow Double  
 AP160DR Red Double  
 AP160CB Check Blue  
 AP160CR Check Red  
 AP160BS Blue stars  
 AP160RH Red Hearts  
 AP160US USA

\* Gift packaged

### Travels Light / AP161

Ø 30 x 18 cm, Ø 11,80 x 7,10"

AP161D Blue  
 AP161E Rainbow  
 AP161F Rainbow Pastel  
 AP161G True Green  
 AP161K Black  
 AP161L Lavender  
 AP161M Mint  
 AP161P Pink  
 AP161R True Red  
 AP161W White/Ivory  
 AP161Y True Yellow  
 AP161DB Blue Double  
 AP161DG Green Double  
 AP161DY Yellow Double  
 AP161DR Red Double  
 AP161CB Check Blue  
 AP161CR Check Red  
 AP161BS Blue stars  
 AP161RH Red Hearts  
 AP161US USA

### Royal Aero / AP163

Ø 56 x 32 cm, Ø 22 x 12,60"

AP163D Blue  
 AP163E Rainbow  
 AP163F Rainbow Pastel  
 AP163G True Green  
 AP163K Black  
 AP163L Lavender  
 AP163M Mint  
 AP163P Pink  
 AP163R True Red  
 AP163W White/Ivory  
 AP163Y True Yellow  
 AP163DB Blue Double  
 AP163DG Green Double  
 AP163DY Yellow Double  
 AP163DR Red Double  
 AP163CB Check Blue  
 AP163CR Check Red  
 AP163BS Blue stars  
 AP163RH Red Hearts  
 AP163US USA

### Jules Verne / AP168

Ø 70 x 42 cm, Ø 27,60 x 16,50"

AP168D Blue  
 AP168E Rainbow  
 AP168F Rainbow Pastel  
 AP168G True Green  
 AP168M Mint  
 AP168R True Red  
 AP168W White/Ivory

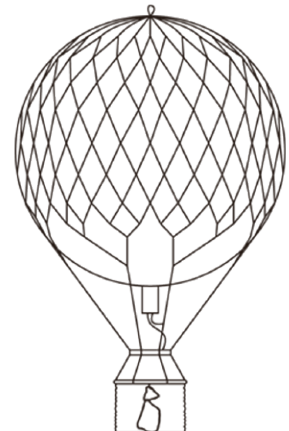
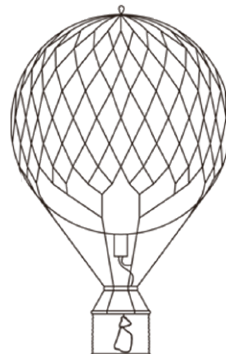

# Festive Metallic in Gold and Silver finish



Silver Red



Silver Navy



Silver Green



Silver Ivory



Silver Blue



Silver Black



Silver Pink



Gold Red



Gold Navy



Gold Green



Gold Ivory



Gold Blue



Gold Black



Gold Pink



### Floating The Skies

Ø 13 x 8,50 cm, Ø 5,30 x 3,30"

- AP160SR Silver Red
- AP160SN Silver Navy
- AP160SG Silver Green
- AP160SI Silver Ivory
- AP160SB Silver Blue
- AP160SK Silver Black
- AP160SP Silver Pink
- AP160GR Gold Red
- AP160GN Gold Navy
- AP160GG Gold Green
- AP160GI Gold Ivory
- AP160GB Gold Blue
- AP160GK Gold Black
- AP160GP Gold Pink

\*Gift packaged



### Travels Light

Ø 30 x 18 cm, Ø 11,80 x 7,10"

- AP161SR Silver Red
- AP161SN Silver Navy
- AP161SG Silver Green
- AP161SI Silver Ivory
- AP161SB Silver Blue
- AP161SK Silver Black
- AP161SP Silver Pink
- AP161GR Gold Red
- AP161GN Gold Navy
- AP161GG Gold Green
- AP161GI Gold Ivory
- AP161GB Gold Blue
- AP161GK Gold Black
- AP161GP Gold Pink



### Royal Aero

Ø 56 x 32 cm, Ø 22 x 12,60"

- AP163SR Silver Red
- AP163SN Silver Navy
- AP163SG Silver Green
- AP163SK Silver Black
- AP163GR Gold Red
- AP163GN Gold Navy
- AP163GG Gold Green
- AP163GB Gold Blue
- AP163GK Gold Black
- AP163GP Gold Pink

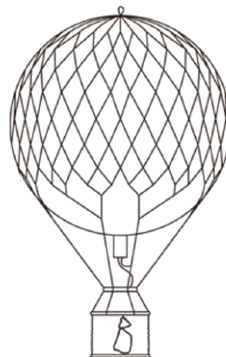

### Jules Verne / AP168

Ø 70 x 42 cm, Ø 27,60 x 16,50"

- AP168SB Silver Blue
- AP168SP Silver Pink

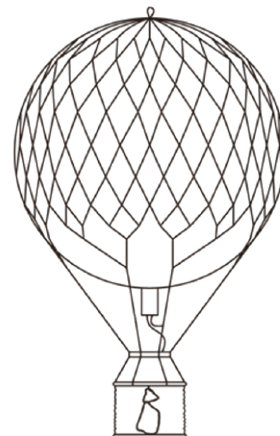



# NAUTICAL

Exploration, embarking on new lives, enjoying leisure trips and sporting endeavour... are just some of the many reasons people have taken to the water over the centuries. For every past-time and purpose, numerous different vessels have been designed to ride the waves, sail the waterways and defeat the competition. Authentic Models celebrates adventure, luxurious travel and challenge of waterborne pursuits through accurate, high-quality models of sailing ships, steamers, runabouts and decorative oars. Staying true to history, while also offering original decorative twists.



America was a 19th-century racing yacht and first winner of the America's Cup international sailing trophy. On August 22, 1851, America won the Royal Yacht Squadron's 53-mile (85 km) regatta around the Isle of Wight by 18 minutes. The Squadron's "One Hundred Sovereign Cup" or "£100 Cup", sometimes mistakenly known in America as the "One Hundred Guinea Cup," was later renamed after the original winning yacht.



**America's Cup Columbia 1901, Small / AS108F**

M. 94 x 13 x 90 cm, 37 x 5,10 x 35,40"

Bluenose II is a replica of the fishing schooner Bluenose, was commissioned by Sidney Culverwell Oland and built in 1963 as a promotional yacht for Oland Brewery. Sidney Oland donated the schooner to Nova Scotia in 1971 and it became Nova Scotia's sailing ambassador.



**America, Small / AS137**

M. 83,80 x 14 x 71,10 cm, 33 x 5,50 x 28"

1900s racer Columbia. Strong and commanding presence at relatively low cost. Classic sailing ship lines, historic America Cup racer. Attention to detail has earned AM world leadership in sailing ship model reproductions. All models are built plank-on-frame and all have cotton hand stitched sails, brass hardware and table stands. Wall brackets sold separately.



**Bluenose II Painted / AS138**

M. 119,40 x 22,90 x 104 cm, 47 x 9 x 41"

“Don't float through life,  
make some waves.”



AUTHENTIC  
NEW  
MODELS

Pen Duick was build in 1898 and really successful in regatta's till the '30's.

Pen Duick is the name most well known for a series of ocean racing yachts sailed by French yachtsman Eric Tabarly. Meaning *coal tit* (a bird species) in Breton it was the name Tabarly's father, Guy Tabarly, gave to the 1898 Fife gaff cutter he purchased, and that his son learned to sail. He thereafter used the name for a series of successful racing yachts through the '60s and '70s.

**Pen Duick, Dark Green / AS053**

M. 67,30 x 12,70 x 78 cm, 26,50 x 5 x 30,70"



AUTHENTIC  
NEW  
MODELS

---

**Endeavour Classic Wood / AS156**

M. 61 x 11,40 x 80 cm, 24 x 4,50 x 31,50"

---



---

**Mini Pond Yachts, Set 4 / AS057A**

M. 51 x 8 x 50 cm, 20,10 x 3,10 x 19,70"

---

An Authentic Models classic, a must-have. Four colored mini pond yachts to sell as a set or individually. Yacht quality lacquer finish. Wood hull, cotton sails, wood stands.



**Endeavour L60, Red/White / AS154**

M. 61 x 11,40 x 80 cm, 024x 4,50 x 31,50"

Endeavour is a 130-foot (40 m) J-class yacht built for the 1934 America's Cup by Camper and Nicholson in Gosport, England. She was built for Thomas Sopwith who used his aviation design expertise to ensure the yacht was the most advanced of its day with a steel hull and mast. She was launched in 1934 and won many races in her first season including against the J's Velsheda and Shamrock V. She failed in her America's Cup challenge against the American defender Rainbow but came closer to lifting the cup than any other until Australia II succeeded in 1983.

“ A smooth sea never made a skillful sailor.”



**Endeavour L60, Black/White / AS155**

M. 61 x 11,40 x 80 cm, 024x 4,50 x 31,50"



Shamrock was a racing yacht built in 1898 that was the unsuccessful Irish challenger for the 1899 America's Cup against the United States defender, Columbia. Shamrock (also known as Shamrock I, to distinguish her from her successors) was built in 1898 under a shroud of secrecy, and christened by Lady Russell of Killowen at its launch on 26 June 1899. Shamrock featured a composite build, with manganese-bronze bottom and aluminium topside clinkerbuilt over a steel frame and a pine decking

---

**Shamrock Yacht Wood / AS157**

M. 100,30 x 17,80 x 123,20 cm, 39,50 x 7 x 48,50"

---

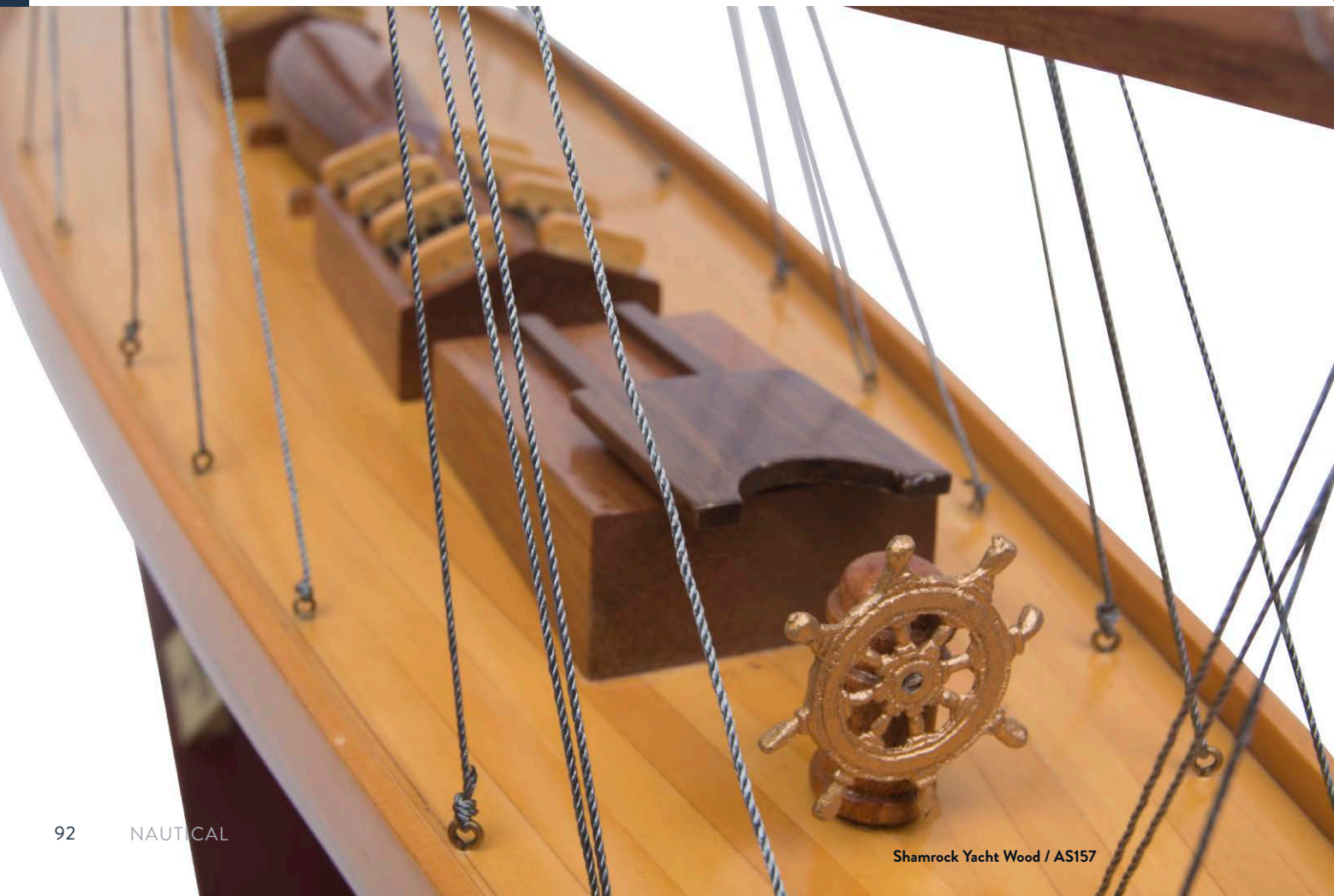



USS Constellation / AS159

USS Constellation was a nominally rated 38-gun wooden-hulled, three-masted frigate of the United States Navy. She was built under the direction of David Stodder at The Joseph and Samuel Sterett shipyard on Harris Creek in Baltimore's Fell's Point maritime community, and she was launched on 7 September 1797. She was one of the original six frigates whose construction the Naval Act of 1794 had authorized. The name "Constellation" was among ten names submitted to President George Washington by Secretary of War Timothy Pickering in March of 1795 for the frigates that were to be constructed. The Flag Act of 1777 speaks of how the stars in the flag are "representing a new constellation".

• AUTHENTIC  
NEW  
MODELS •



USS Constellation / AS159  
M. 96,50 x 30,50 x 88 cm, 38 x 12 x 34,60"





“ Life is better  
on a boat. ”

Triple Cockpit / AS183

The Aquarama has become a nautical legend. Its evocative name and shape conjures images from another time when these boats roared across the Lago di Como and skimmed the Mediterranean waves off St. Tropez... The Jaguar XK120 ruled the road; Doris Day and Cary Grant were Oscar nominated. It was a time of peace, and optimism was unbridled... It was then that Rivas roared across the Lago di Como and skimmed the Mediterranean waves off St. Tropez.



---

**Aquarama / AS182**

M. 64 x 20 x 19 cm, 25,20 x 7,90 x 7,50"

---





The throaty growl of that big engine built inside gleaming mahogany, rich leather, chrome trim. Leather padded seats displayed movie stars trying out the new bikini fashions. Husband number 3, 4, or 5 behind the wheel, decked out in spotless captain's finery. No Coast Guard was able to overtake these sleek twin-engine torpedo shaped racers. The curves, the looks, the excitement, the opulence... Stateside, the luxurious Chris Crafts were de rigeur with Hollywood elite.



**Triple Cockpit / AS183**  
M. 64 x 20 x 19 cm, 25,20 x 7,90 x 7,50"



**Titanic / AS083**

M. 91,50 x 18 x 36 cm, 36 x 7 x 14,25"



**Tramp Steamer 'Rangoon' / AS300**

M. 64 x 31,25 x 4,50 cm, 25 x 12,25 x 1,75"

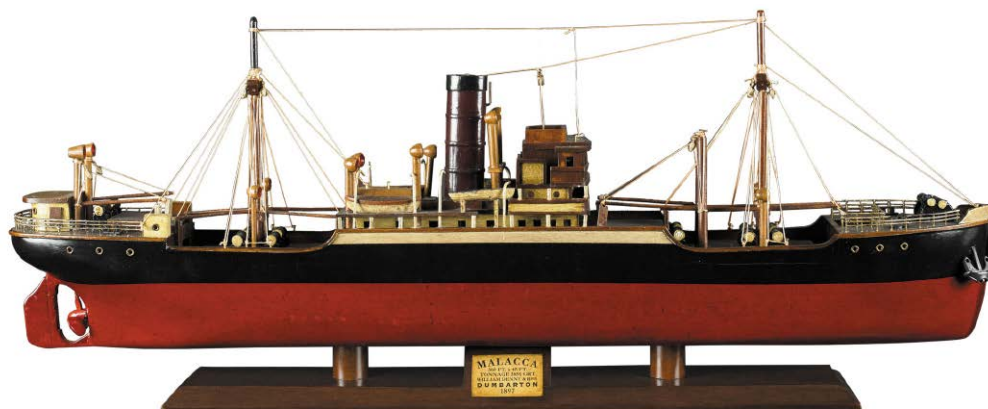

**Tramp Steamer 'Malacca' / AS303**

M. 68 x 27 x 7 cm, 26,50 x 10,25 x 2,75"



**TITANIC**

# RMS Titanic

Once the largest man-made moving object on Earth, with interiors inspired by the London Ritz hotel, its own on board newspaper and musicians with a repertoire of 352 songs, the RMS Titanic represented the pinnacle of endeavour and luxury. This attentively crafted model recreates the vessel in fascinating external detail.

**WHITE STAR LINE**  
 ROYAL & UNITED STATES MAIL STEAMERS

FIRST SAILING OF THE LATEST ADDITION TO THE WHITE STAR FLEET  
**The Queen of the Ocean**  
**TITANIC**

LENGTH 882½ FT.    OVER 45,000 TONS    BEAM 92½ FT.  
 TRIPLE-SCREWS

This, the Latest, Largest and Finest Steamer Afloat, will sail from  
**WHITE STAR LINE, PIER 10, SOUTHAMPTON**  
**WEDNESDAY, APRIL 10<sup>TH</sup>**

*en route to NEW YORK*



Oars make a large statement home décor pieces, which work in many environments. Place them in your beach house on your porch. Frame a doorway or place above the kitchen worktop to hang pots and pans.



**Tender Oar, Red / FE105**  
M. 182 x 13,50 x 8 cm, 71,70 x 5,30 x 3,10"



**Tender Oar, Ivory / FE106**  
M. 182 x 13,50 x 8 cm, 71,70 x 5,30 x 3,10"



**Tender Oar, Blue / FE107**  
M. 182 x 13,50 x 8 cm, 71,70 x 5,30 x 3,10"





**Royal Barge Rack 4 / FE130**

M. 69 x 7 x 9 cm, 27,15 x 2,75 x 3,55"



**Lifeboat Oar / FE103**

M. 184,25 x 14 x 4 cm, 72,50 x 5,50 x 1,60"



**Oxford Varsity / FE104**

M. 235 x 16,50 x 5 cm, 92,50 x 6,50 x 2"



**Royal Barge Oar # 1 / FE123**

M. 14 x 4,50 x 145 cm, 5,50 x 1,75 x 56,70"



**Royal Barge Oar # 2 / FE124**

M. 14 x 4,50 x 145 cm, 5,50 x 1,75 x 56,70"



**Royal Barge Oar # 3 / FE125**

M. 14 x 4,50 x 145 cm, 5,50 x 1,75 x 56,70"



**Royal Barge Oar # 6 / FE129**

M. 14 x 4,50 x 145 cm, 6 x 1,75 x 46,25"



Finally! 1930s A-Cup yachts racing in the air. Four colored J-Yacht miniatures made of solid wood and cotton sails... Ever so graceful, even at this size the miniatures are authentic and correct in their details.



---

**A-Cup Mobile / AS130**

M. 93 x 3,50 x 32 cm, 36,60 x 1,40 x 12,60"

---



---

**Sunset Sailers, Set Of 4 / AS170**

M. 26,10 x 7,10 x 40,50 cm, 10,30 x 2,80 x 16,10"

---

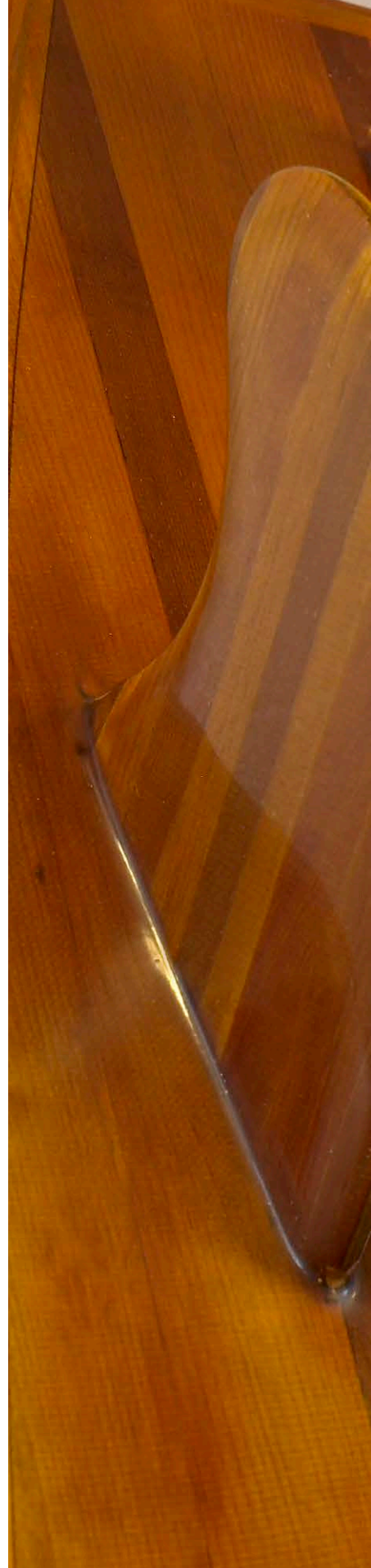



“See you on  
the next wave.”

Only a few craftsmen now have the skills needed to build a classic wooden surfboard. Long enough to ride the wave off Waikiki or Malibu. Just short enough to casually lean into a corner of your living room, study, or den... Boards are made of laminated strips of selected light woods. Three fins are included for improved stability. The board is finished with a thin epoxy skin, allowing use on that tropical beach that is calling you!



**Waikiki Surfboard / FE121**

M. 195 x 50 x 18 cm, 76,80 x 19,70 x 7,10"



# CARS

Motoring started to really find its feet in the 1930s when engineering and competitive spirit came together in the form of racing cars. While careering round a track was only for the very bravest of men, mere mortals could get a safer slice of the action by racing spindizzies – miniature tether cars modelled equal in size on racing cars which moved at nearly 70 miles per hour. Authentic Models salutes those heady early days of motorsport with wonderfully detailed models of the cars and spindizzies which so captured the hearts of their fans.



The 1930s saw the rise of hand built model racecars, known as spindizzies or tether cars. Miniature racecars built by hobbyists zoomed around banked wooden tracks at speeds approaching 70 miles per hour. Resembling the full-size racers of their day, several spindizzies competed at once, tethered by cables to a central pole. Powered by model airplane engines, spindizzies raced against the clock. Incredibly detailed and aerodynamic, these miniature racecars were beyond toys; they were pieces of art representative of the best pioneering technology of the era. Constructed using original blueprints, our Bantam Midget model resembles the original down to the smallest detail. One look and you'll be ready to join the competition.



---

**Bantam Midget, Red / PC012**

M. 48 x 22 x 18 cm, 18,90 x 8,70 x 7,10"

---



**Bantam Midget, Red / PC012**

AUTHENTIC  
NEW  
MODELS



**Bantam Midget, Green / PC012G**  
M. 48 x 22 x 18 cm, 18,90 x 8,70 x 7,10"



**Bantam Midget, 19" / PC011**

Spindizzies, named for the dizzying speeds they reached, were inspired by full size racecars. Handcrafted, large-scale miniatures were made by skilled owners, who often spent hundreds of hours on each car. Cherished by their owners, they now are coveted by collectors the world over. Our Bantams are truly hand tooled, traditionally die stamped body parts, in aluminum, brass and polished mahogany wood. Lift the hood; admire the replica engine. Turn the cockpit wheel and angle the front wheels. Smell the luxurious leather of the driver's seat. This is a touch of car history at its best.

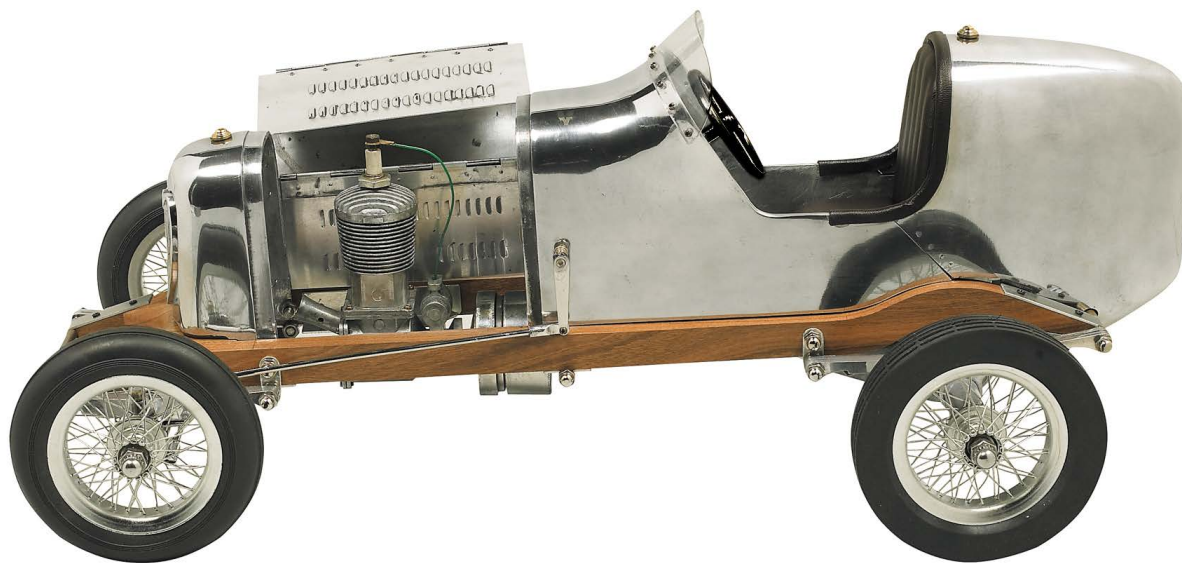

**Bantam Midget, 19" / PC011**

M. 48 x 22 x 18 cm, 18,90 x 8,70 x 7,10"

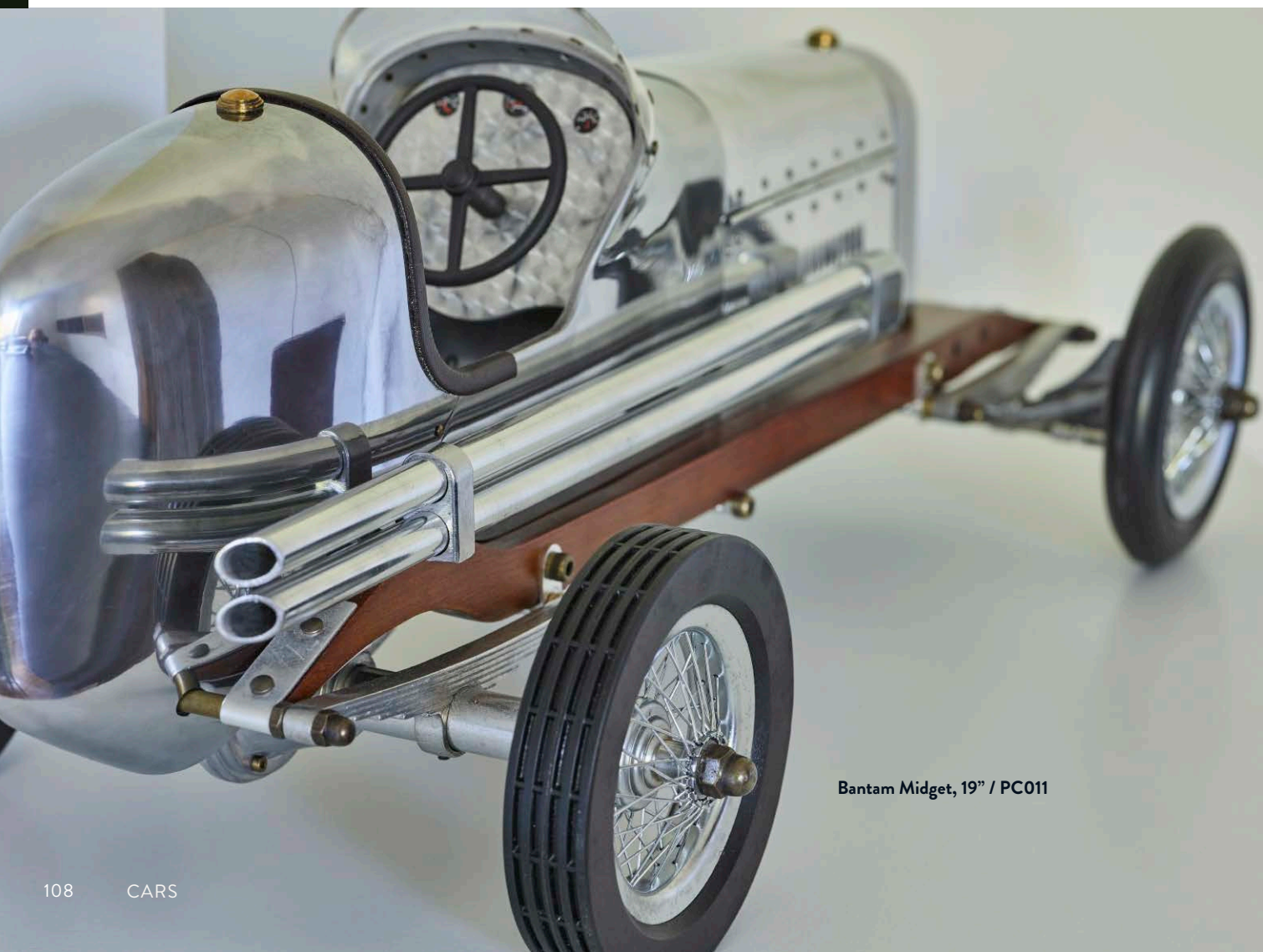

**Bantam Midget, 19" / PC011**

# Spindizzies

Technically skilled enthusiasts of the 1930s loved to race the legendary B.B. Korn cars around the club tracks. Called tether cars or spindizzies, they reached incredible speeds, and inspired thousands to improve and invent. The founder of the B.B. Korn Manufacturing Company, Barney Korn, produced several tether car models that now, as vintage antiques, achieve astounding sums at auction.

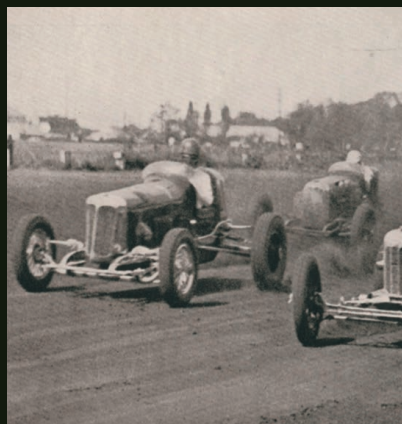

**BB Korn / PC013**

M. 52,50 x 24,50 x 17,50 cm, 20,75 x 9,75 x 7"

# Surprising racingcars

Surprisingly sophisticated racecars in 1:8 scale raced tethered to a pole or to a chain track in a banked wooden racetrack, reaching speeds in excess of 150 mph... Imagine a corner of the 1939 New York World's Fair. A throng of thousands massing around a mini car-drome where racecars are being prepared for a major race. The scream of the engines fills the air. A mini NASCAR, Le Mans, Nuburgring... An American pastime; technology, cars, excitement! Spindizzies, named for the dizzying speeds they reached, were inspired by full size racecars.



BB Korn, Red / PC013R



---

**BB Korn, Red / PC013R**

M. 52,50 x 24,50 x 17,50 cm, 20,75 x 9,75 x 7"

---



---

**BB Korn, Green / PC013G**

M. 52,50 x 24,50 x 17,50 cm, 20,75 x 9,75 x 7"

---



Indianapolis, White/black / PC010W

# Grand Prix Racers

This shiny, sleek desktop racer represents both the romance and the dramatic beauty of the most famous Grand Prix racers ever. In keeping with its original model-toy character, the front wheels are not linked to the steering wheel. The wheel hubs and rubber tires are made with the same exact detail as the original.

AUTHENTIC  
NEW  
MODELS



Indianapolis, Red Seat / PC010R  
M. 31 x 13 x 9 cm, 12,20 x 5,10 x 3,50"



Indianapolis, White/black / PC010W  
M. 31 x 13 x 9 cm, 12,20 x 5,10 x 3,50"

In 1934, the international motor sport governing body specified a maximum weight for Grand Prix racing cars of 750 kg, excluding tyres and fuel. The Germans decided to reduce weight by removing the lead-based paint which denoted its cars' traditional white livery, exposing distinctive shining aluminium. Victory by one of these lead to the nickname Silver Arrow. Their successors, which were built on the same chassis, continued to race successfully at the Indy 500 after the war.



\*Gift pachaged



**Silberpfeil / PC014**

M. 31 x 14,60 x 9 cm, 12,25 x 5,75 x 3,50"



**Silberpfeil Black, Red Seat / PC014B**

M. 31 x 14,60 x 9 cm, 12,25 x 5,75 x 3,50"



**Silberpfeil, Red Seat / PC014R**

M. 31 x 14,60 x 9 cm, 12,25 x 5,75 x 3,50"



**Blue Racer / PC016**

M. 31 x 14,60 x 9 cm, 12,25 x 5,75 x 3,50"



# GLOBES

A beautifully handcrafted globe is both a work of art and a historical reference point. With different versions through the centuries reflecting new knowledge gained by explorers and new territories claimed by countries. Authentic Models is a world leader in antique globe reproduction, still practicing the traditional complex gravure printing technique developed to display fine details. Our collection represents five centuries of globe development by some of the greatest names in cartography, tastefully mounted on sympathetically designed stands to bring old world charm to even the most modern settings.





**Trianon Globe / GL045**

M. Ø 14 x 27,50 x 14 cm, Ø 5,50 x 10,80"



**The Earth & The Heavens / GL032**

M. Ø 8,50 x 10,50cm, Ø 3,30 x 4,10" Gift Packed



**Mini Terrestrial Globe / GL015**

M. Ø 12 x 22cm, 4,72 x 8,66"



**Vaugondy Sphere, Ivory, 14cm / GL212**

M. Ø 14 cm, 5,50"



**Vaugondy Globe 1745 / GL021F**

M. Ø 14 x 29,50 cm, 5,50 x 11,75"



**Vaugondy, Ivory, 18cm / GL312**

M. Ø 18 cm, 5,50"



---

**1745 Vaugondy Globe In A Box, Small / GL027**  
M. Ø 8,50 x 9 cm, 3,50 x 3,30" Gift Packed

---



---

**The Age Of Exploration Keepsake / GL031**  
M. Ø 8,50 x 10,50 cm, 4,10 x 3,30" Gift Packed

---



---

**Vaugondy Sphere, Black, 14cm / GL211**  
M. Ø 14 cm, 5,50"

---



---

**Vaugondy Sphere, Color, 14cm / GL213**  
M. Ø 14 cm, 5,50"

---



---

**Vaugondy, Black, 18cm / GL311**  
M. Ø 18 cm, 5,50"

---



---

**Weber Costello / GL313**  
M. Ø 18 cm, 5,50"

---



**1920s Globe 32 cm / GL043**  
M. Ø 32 x 50 cm, 12,60 x 19,70"



**Vaugondy Hanging L / GL071**  
M. Ø 32 cm, 12,60" Incl, 3 hooks



**Vaugondy Hanging S / GL074**  
M. Ø 18 cm, 5,5" Incl, 3 hooks



**Vaugondy 1745, Classic Stand / GL008D**  
M. Ø 34,50 x 61 x 34,50 cm, 24"



**Library Globe / GL047**  
M. Ø 48 x 96 cm, 18,90 x 37,80"

# Vaugondy

Gilles Robert de Vaugondy and his son, Didier Robert de Vaugondy, were the leading mapmakers in France during the 1700s. Didier was appointed geographer to Louis XV in 1760 and published globes of various sizes, the biggest with a diameter of 2.6 meters. Carrying science and history into the world of home décor. A unique combination of classic globe replica from historical cartography with spectacular decorative stands.



AUTHENTIC  
NEW  
MODELS

**Vaugondy Vintage Round / GL062**

M. 36 x 32 x 44 cm, 14,20 x 12,60 x 17,30"

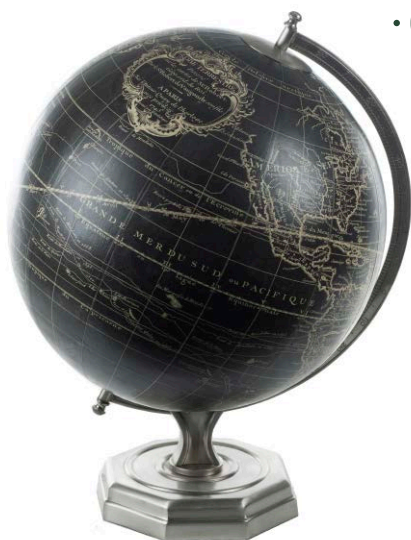

AUTHENTIC  
NEW  
MODELS

**Vaugondy Vintage Half / GL065**

M. 34 x 32 x 44 cm, 13,40 x 12,60 x 17,30"



**Vaugondy 1745 Noir / GL041**

M. Ø 32 x 50 cm, 12,60 x 19,70"

# Weber Costello

The world in 1921, roaring and still colonial. The Weber Costello globes are displayed on ebonized wood stands. Colored gores are applied to the globe by hand with authentic construction and detail which transforms them into contemporary classics.



**Versailles Globe /GL044**

M. Ø 14 x 26,25 cm, 5,50 x 10,80"



**Weber Costello Globe /GL036**

M. 32 x 32 x 50 cm, 12,60 x 12,60 x 19,70"



**1921 USA Globe, Weber Costello / GL026**

Ø 18 cm M. 18 x 18 x 30,50 cm, 12 x 7,10"



**Weber Costello Hanging S /GL075**

M. Ø 18 cm, 5,5" Incl, 3 hooks



**Weber Costello Hanging L /GL072**

M. Ø 32 cm, 12,60" Incl, 3 hookshooks

A contemporary classic. The 1920s Weber Costello globe is displayed on a vintage silver stand. Colored gores are applied to the globe core by hand with authentic construction and detail.



**Weber Costello Vintage Round /GL063**

M. 36 x 32 x 44 cm, 14,20 x 12,60 x 17,30"



**Weber Costello Vintage Half /GL066**

M. 34 x 32 x 44 cm, 13,40 x 12,60 x 17,30"

# Hondius

Legendary cartographer, Jodocus Hondius, worked in Amsterdam during the 1600s, then one of the world's commercial hubs. Spin the world and enjoy a touch of true history. Galleons sailing oceans to the farthest corners of the then known world. Exotic cultures, languages, people and goods to be traded, bought and sold. Gold and ivory, spices and silks.



**RMN 19th C. 18cm Globe / GL055**

M. Ø 18 x 31 cm, 7,10 x 12"

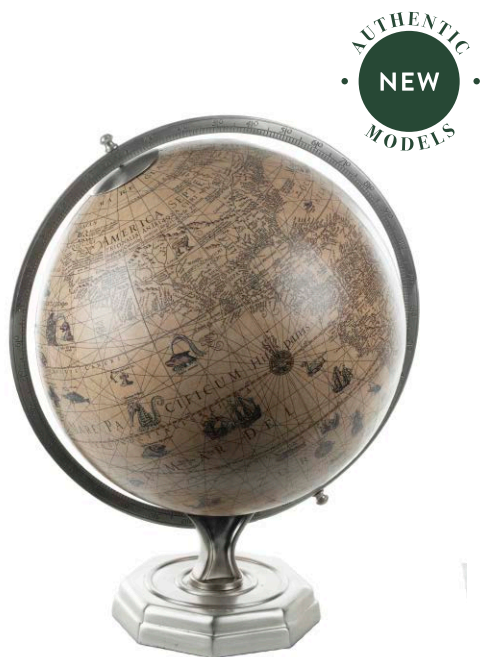

**Hondius Vintage Round / GL064**

M. 36 x 32 x 44 cm, 14,20 x 12,60 x 17,30"

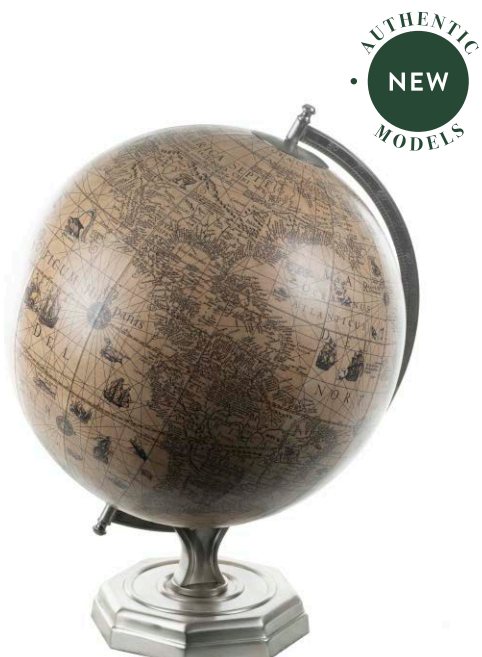

**Hondius Vintage Half / GL067**

M. 34 x 32 x 44 cm, 13,40 x 12,60 x 17,30"



AUTHENTIC  
NEW  
MODELS

**Hondius Hanging S / GL076**

M. Ø 18 cm, 5,5"



**Dragon Globe / GL054**

M. Ø 32 x 53,50 cm, 12,60 x 21"

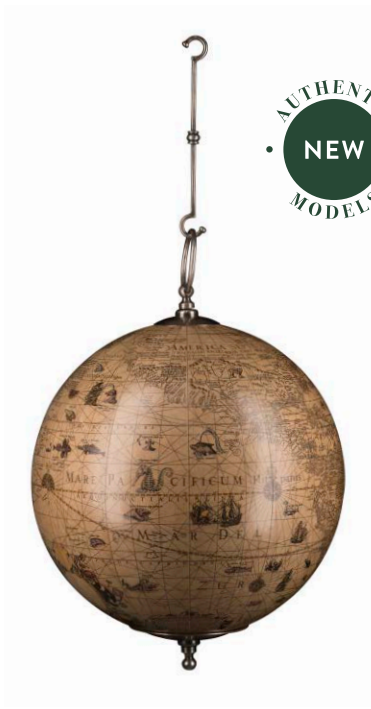

AUTHENTIC  
NEW  
MODELS

**Hondius Hanging L / GL073**

M. Ø 32 cm, Ø 12,60"



**Hondius 1627, Classic Stand / GL003D**

M. Ø 34,50 x 61 cm, 13,60 x 24"

# Mercator

Hand applied gores from the famous Dutch cartographer, Gerardus Mercator, engraved charts from 1541. Made in cooperation with the Royal Library in Bruxelles.



**Student Globe / GL042**

M. Ø 11 x 19,50 cm, 4,25 x 7,75"



**Terrestrial Globe With Compass / GL019**

M. Ø 14,50 x 21 cm, 8,30 x 5,70"

Decorative and well-executed globe from the age of exploration. Stand is detailed turned wood, French finish. Exact reproduction of 16th C. Mercator globe, hand applied paper gores.



**Navigator's Terrestrial Globe / GL023F**

M. Ø 26,50 x 29,75 cm, 11,80 x 10,40"



**Mercator 1541, Classic Stand / GL002D**

M. Ø 34,50 x 61 cm, 24 x 13,60"



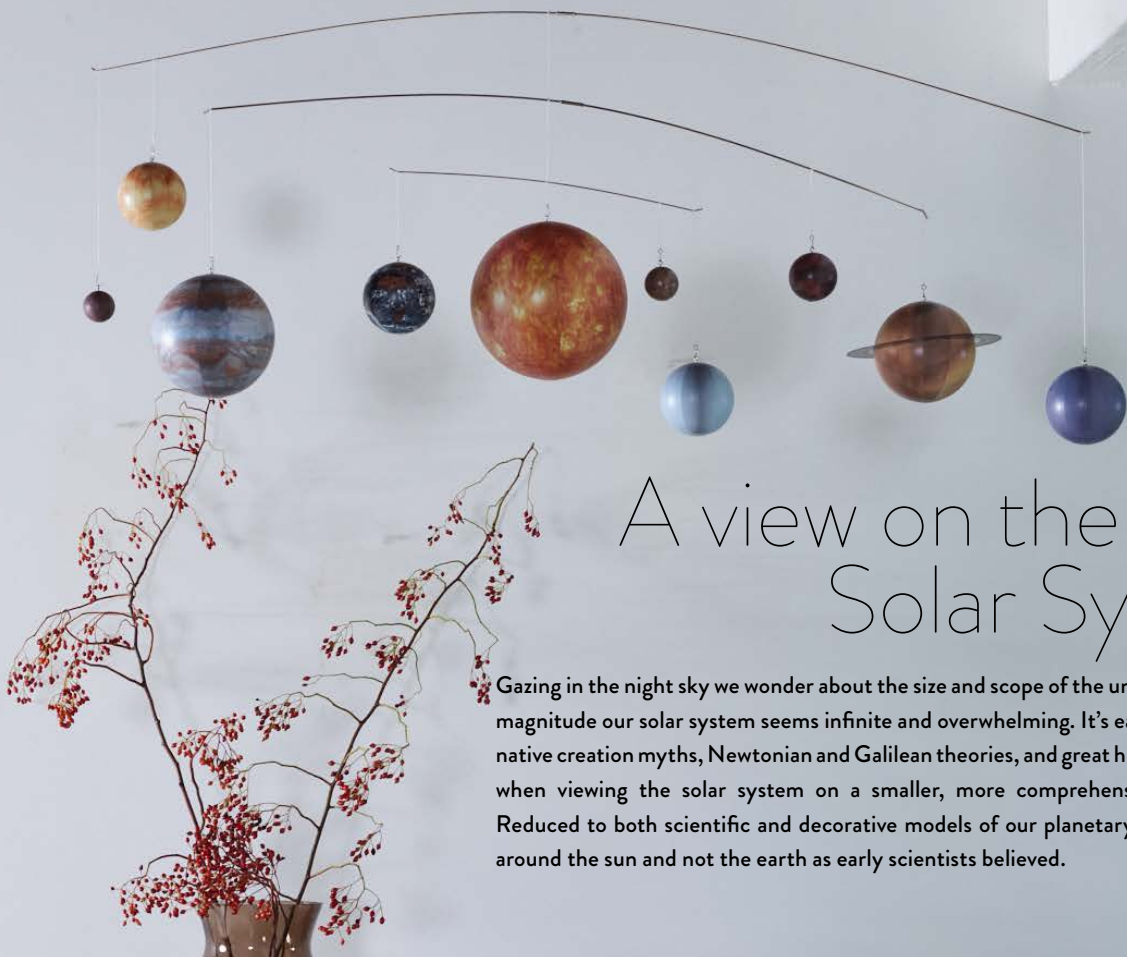

# A view on the Solar System

Gazing in the night sky we wonder about the size and scope of the universe. Within that magnitude our solar system seems infinite and overwhelming. It's easier to understand native creation myths, Newtonian and Galilean theories, and great historical discoveries when viewing the solar system on a smaller, more comprehensible human scale. Reduced to both scientific and decorative models of our planetary system, revolving around the sun and not the earth as early scientists believed.

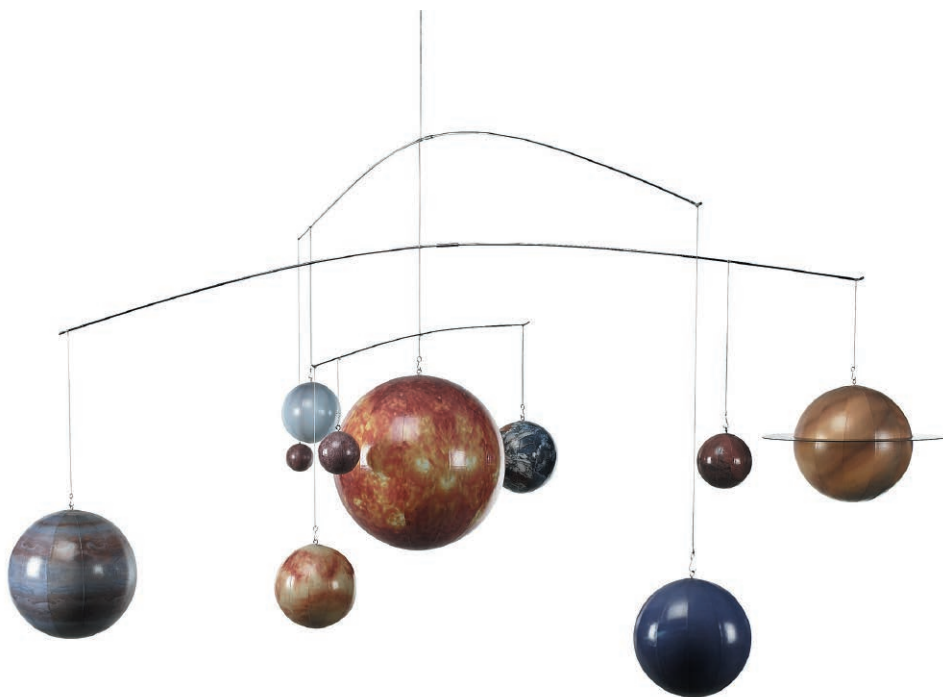

## Mobile Solar System / GL061

M. 51 x 135 x 45 cm, 20,10 x 53,10 x 17,70"



---

### Globe Mobile / GL060

M. 108 x 18 x 90 cm, 42,50 x 7,10 x 35,40"

---

# Globe Mobile Magic Object

Five different globes from five centuries, symbolizing the advancement of cartography, the gradual pushing back of boundaries. Seemingly a magic object, many earth globes moving in perpetual circles. Different style globes in colors, hues and specifications make a fascinating and elegant object. Sure to arouse interest in planets and their clockwork movements in a curious child's mind.



As a scientific symbol, our bookends add a touch of distinction to home and office. Matching celestial and terrestrial globes dating back to the 16th C. Bronze mountings and French finished stands.



**Globe Bookends / GL009F**

M. 36 x 13 x 25 cm, 14,20 x 5,10 x 9,80"



**Duotone Bronze Globe Base / GL200B**

M. Ø 11 x 1,50 cm, 4,30 x 0,60"



**Aluminum Globe Base / GL200A**

M. Ø 11 x 1,50 cm, 4,30 x 0,60"



**Desk Stand For Globe / GL000**

M. Ø x 11 x 17,50 cm, 4,30 x 6,90"



**Globe Base, Wood / GL200**

M. Ø 11 x 1,50 cm, 4,30 x 0,60"

“Wisdom begins  
with wonder.”

An interesting mix of early science and Greek mythology. One of the legendary Titans battling Zeus was defeated and decreed to carry the weight of the world on his mighty shoulders. Forever... Our armillary dial, however, has Atlas carrying the entire universe. Gracefully intertwined silver rings symbolize the position and trajectories of heavenly bodies around the earth.



**Bronze Armillary Dial / GL052**

M. Ø 18,50 x 36,50 cm, 7,30 x 14,40”



**18th C. Atlas Armillary / GL051**

M. Ø 25,50 x 56 cm, 10 x 22”



# LIFESTYLE

In a world of fast-everything, there's something beautifully grounding about hobbies, interests, recreational activities and daily routines from bygone eras. Authentic Models creates delightful functional and decorative items which embody the passion, pride and craftsmanship of yesteryear. Combining historic character with modern day flair in original, tastefully designed objects. Always crafted out of the highest quality materials.



An architectural helix curving up to heaven. Gorgeous and inspired, time-less décor. Based in history, when cabinetmakers passed their finals by creating precious miniature models. Modern in that they complement contemporary taste and décor. Admire the intricate way this free-spiraling stairways are constructed.



**Duomo Due / AR014**

M. 25,50 x 25,50 x 62 cm, 10 x 10 x 24,50"



**Nirvana Spire / AR041**

M. Ø 26,50 x 55 cm, 10,50 x 21,75"



**Spiral Stairs / AR019**

M. Ø 20,50 x 37,50 cm, 8,10 x 14,80"



**Buri Tower / AR067**

M. 20 x 20 x 54 cm, 7,90 x 7,90 x 21,25"



**Demi-Dome / AR015**

M. 46 x 25 x 41 cm, 18 x 9,75 x 16"



**Galat Tower / AR066**

M. 35 x 18 x 73 cm, 13,80 x 7,10 x 28,75"





**The Duke of Malfi / MC066**

M. 14,50 x 6,50 x 20,50 cm, 5,75 x 2,50 x 8,25" Gift Packed



**Gift Package**



One of the greatest classic theatre tragedies from English history is the story of the Duke and Duchess of Malfi. This story of a beautiful Duchess who absconds with a common lover, leaving the Palace of Pleasures. A classic and famous story... Also a story that appealed to masked participants of the yearly Venetian Commedia dell' Arte season which lasted for months... Our sculptured masks represent an age when elegance and sophistication mixed with a need for secrecy and pretense. The 'Bouffon' or Jester is an unusually rich and decorative representation of one of the most ubiquitous of Venetian Carnival characters.



**Bouffon Venice / MC068**

M. 15 x 10 x 23 cm, 6 x 4 x 9" Gift Packed



**The Dutchess of Malfi / MC067**

M. 8,50 x 6 x 21,50 cm, 3,50 x 2,25 x 8,50" Gift Packed



---

**Doorstop Cotton / HD001**

M. Ø 20 x 22 cm, 7,90 x 8,70"

---



---

**Doorstop Sisal / HD002**

M. Ø 20 x 22 cm, 7,90 x 8,70"

---



---

**Monkey's Fist/Shackle / FW003**

M. 12 x 3 x 4 cm, 4,70 x 1,20 x 1,60"

---





AUTHENTIC  
NEW  
MODELS



**Funnel Waste Basket, Red / RL001R**

M. 35 x 25 x 33 cm, 13,75 x 9,75 x 13"

AUTHENTIC  
NEW  
MODELS



**Funnel Waste Basket, White / RL001W**

M. 35 x 25 x 33 cm, 13,75 x 9,75 x 13"

Classic bosun whistle makes deck hands happy. To man the sails, go aloft, or defend the ship in action, “All hands on deck” was one of the commands blown by the Bosun’s Mates on this whistle or “call”. Its shape hasn’t changed in five centuries.



**Bosun's Whistle / BW001**

M. 13 x 2 x 1 cm, 5,10 x 0,80 x 0,40"



**Victorian Whistle / BW002**

M. 5 x 2 x 2 cm, 2 x 0,75 x 0,75"



**White Star Call / BW003**

M. 5 x 2 x 2 cm, 2 x 0,75 x 0,75"





A poster image of a 19th C. gentleman bon vivant, posed cane in hand on a seaside walkway, provides a fitting backdrop for your own walking stick display. Holds up to four sticks.



**Telescope Walking Stick / WS005**

M. 5 x 5 x 98 cm, 2 x 2 x 38,50"



**Time Companion / WS006**

M. 6,50 x 6,50 x 88 cm, 2,60 x 2,60 x 34,60"



**Captain's Walking Stick / WS002**

M. 3,50 x 3,50 x 92 cm, 1,40 x 1,40 x 36,20"



**Dandy Stand / WS000**

M. 7 x 30,50 x 68 cm, 12 x 2,75 x 26,75"



# Rocking Horse

The classic rocking horse: no upper class children's playroom was without one. Some were mounted on oval wood rockers, others on a 'safety' stand, where steel swings allowed for greater movement on a stationary base. Our iconic rocking horse is a full-sized reproduction of originals dating back to the 19th C. Hand carved in top quality mahogany. Hand made saddle and tack of real bridle leather.

The expert skills of wood carvers, cabinetmakers, and saddlers are evident. Hand finished in a warm and glowing French-style varnish, slightly distressed to make it look somewhat aged. A timeless treasure and a dream-toy for both boys and girls. Imagine its value in 50 years...



---

**Rocking Horse, Western Saddle / RH006W**  
M. 142,50 x 46,50 x 120,50 cm, 56 x 18,30 x 47,50"

---



---

**Victorian Rocking Horse / RH006**  
M. 142,50 x 46,50 x 120,50 cm, 56 x 18,30 x 47,50"

---



**Seeing Stars, Kaleidoscope Kit / MS073A**  
 M. 21,50 x 6,50 x 6,50 cm, 8,60 x 2,60 x 2,60"



**Boat In A Bottle Kit / MS022A**  
 M. 14,50 x 12 x 7 cm, 5,70 x 4,50 x 2,80"

It's like hearing weathered old-time deck-hands telling yarns, sharing their special secrets. To make a ship inside a bottle, to learn the ropes, how to best send a message in a bottle. Where will the currents take it... Yokohama? Zanzibar? So many stories. Uniquely conceived and packaged. Both gift and craft, educational and whimsical. Rare fun in attractive and intriguing boxes. Easy to learn and enjoy. For inquisitive minds... and keeps them busy for hours at a time.



**Compass Journal / MS010A**

M. 13 x 20,50 x 1,80 cm, 5,10 x 8,10 x 0,70"



An explorer's priority, direction...where will the compass lead?

**Mariner's Compass / MS013A**

M. 9,50 x 10 x 3 cm, 3,90 x 3,90 x 1,20"



Our version of the earliest time telling methods. Find a sunny day and have some fun.

**Maritime Pocket Sundial / MS019A**

M. 10,40 x 11 x 1,75 cm, 4,10 x 4,30 x 0,70"



**Traveler's World Globe In Box / MS021A**

M. Ø10 x 8,80 x 10 cm, 4 x 3,50"



**Learn The Ropes / MS071A**

M. 13,75 x 11,75 x 2,50 cm, 5,40 x 4,60 x 1"



**It's A Toss Up / MS054A**

M. Ø 14 x 6 x 14 cm, 5,50 x 2,40"

This solid brass candle lantern is a recreation of a 17th century Renaissance style piece, incorporating the exotic oriental designs which have inspired Italian artisans since the 11th century. While originals have become rare and costly, our reproduction is very affordable.



**Venetian Lantern, Bronze / SL047**

M. 18 x 18 x 34,50 cm, 7,10 x 7,10 x 13,60"



**Venetian Lantern, Antique Silver / SL047A**

M. 18 x 18 x 34,50 cm, 7,10 x 7,10 x 13,60"



**Anchor Lamp, Brass & Copper / SL043**

M. 19 x 15 x 30 cm, 7,50 x 5,90 x 11,80"



**Miner's Lamp / SL109**

M. Ø 10,40 x 25,40 cm, 4,10 x 10"

# Miner's Lamp

Surrounded by darkness, miners had to rely on their lamps as it could be their life saver. This exact reproduction is made to the same highest standards as before.





“At your  
service.”



**Round Reception Bell / AC105**

M. Ø 9,90 x 8,90 cm, 3,90 x 3,50”



**Triangle Base Reception Bell / AC107**

M. Ø 13,70 x 8,90 cm, 5,40 x 3,50”

The original desk bell of the Sailor's Inn. Call the desk agent, request  
First Class service only. A bell with history.



**Sailor's Inn Desk Bell / AC100**

M. Ø 13 x 10,50cm, 5,10 x 4,10”



**Sailor's Inn Desk Bell, Silver / AC100S**

M. Ø 13 x 10,50cm, 5,10 x 4,10”



**Sailor's Inn Desk Bell, Bronze / AC103**

M. Ø 13 x 10,50cm, 5,10 x 4,10”



**Purser's Bell / AC076**

M. 15 x 24 x 20 cm, 6 x 9,40 x 7,90”



**Purser's Bell, Silver / AC076S**

M. 15 x 24 x 20 cm, 6 x 9,40 x 7,90”

The helmsman rings the ship's bell for every half hour of the four-hour ship's watch. A ship is a round-the-clock operation, and ship's crews work four hours on and four hours off. To change the routine two two-hour dogwatches usually run between 4 and 8 PM. One bell - One ring (say 12:30)... Two bells - Two rings (say 1 PM)... etc. until... Eight bells - Eight rings (4PM). AM-Living bells are made of heavy solid brass, handmade and sand-cast. The chunky hand knotted lanyard offers years of use. We offer four sizes of bells, petite to large, for beach house or boat. A true nautical heirloom offering clear & solid sounds.

All bells are made in solid brass with bronze finish.



**Bronze Ship's Bell 5" / AC072B**

Ø 12,75 cm / 5" M. 12 x 12,75 cm, 4,70 x 5"



**Bronze Ship's Bell 6" / AC073B**

Ø 15 cm / 5,90" M. 16,50 x 15 cm, 6,60 x 5,90"



AUTHENTIC  
NEW  
MODELS



\*Gift packaged

**Chess Bottle Stopper Set / BA006**

M. 7,20 x 4,30 x 5,40 cm, 2,85 x 1,70 x 2,10" Gift Package



# Cocktail Shakers

Decorative designs that differed from the classic shaker shape were in fashion, to make them less easily recognized by the police. All this was during the 1920s when the Congress voted in the Prohibition and the US went 'dry'. Illegal bars called speakeasies came in many varieties. To cover up the rough taste of the poor quality alcohol which remained available, bartenders created cocktails with plenty of juices and other sweeteners. All shakers are made of heavily silver-plated brass.



**Thirst Extinguisher C. Shaker / CS001**

M. Ø 10,5 x 38 cm, 4,10 x 15"



**Fire Extinguisher C. Shaker / CS002**

M.Ø 9 x 25 cm, 3,55 x 9,85"



**Lighthouse C. Shaker / CS010**

M. Ø 10,5 x 35,50 cm, 4,10 x 14"

# Porthole Mirror

Heavy, cast aluminum porthole mirror actually opens to the one picture you loved from last year's Bahamas trip....Measuring 15 inches, this aluminum mirror has a bronze finish. An Authentic Models classic.



---

**Belle Epoque Vanity / AC094**  
M. 9 x 12,75 x 33 cm / M. 3,60 x 5 x 13"

---



---

**Cabin Porthole Mirror, Medium / AC188A**  
M. Ø 38 x 7 cm, 15 x 2,80"

---



\*Gift packaged

---

**Victorian Vanity / AC110**  
M. 26,5 x 11,5 cm, 10,5 x 4,5"

---



---

**Lounge Porthole Mirror, Large / AC189A**  
M. Ø 51 x 7cm, 20,10 x 2,80"

---

“Mirror, mirror  
on the wall who  
is the prettiest  
of them all?”



Belle Epoque Vanity / AC094



# Spinning Tops & Board

A subtle finger twist sets the top on its seemingly magic tour across the curved surface of the bowl. Six tops in six colours allow players to compete for the longest spin.

# “Let’s play some games.”

The game of Solitaire is reputed to have been invented by a nobleman confined in the Bastille prison during the early years of the French Revolution. The game is played with 36 marbles. The object is to eliminate all but one marble, which should ideally end up in the center of the game board. Solitaire Di Venezia...individually hand blown glass marbles, full of color, against a solid ebony board. Art in itself, functional and fun as solitaire.



\*Gift packaged

**Solitaire Game 20mm, French Finish / GR005F**  
M. Ø 25 x 3,50 cm, 9,80 x 1,40”



\*Gift packaged

**Solitaire Di Venezia, 25mm Marbles / GR007**  
M. Ø 30 x 3 cm, 11,80 x 1,20”



**Semi-Precious Solitaire Game, 30mm / GR022**  
M. Ø 35 x 9 cm, 13,80 x 3,50”



**Roulette / GR025**  
M. Ø 14 x 8,40 cm, 5,50 x 3,30”



**Spinning Tops&Board / GR026**  
M. Ø 24 x 9 cm, 9,60 x 3,30”



\*Gift packaged

**Venetian Tic-Tac-Toe / GR004**  
M. 22 x 33 x 3,50 cm, 8,70 x 13 x 1,40”



\*Gift packaged

---

**Classic Staunton Chess Set / GR021**

M. 28,50 x 27 x 4,50 cm, 11,20 x 10,90 x 1,70"

---



---

**Backgammon Tray / FF106**

M. 38 x 38 x 5 cm, 15 x 15 x 2"

---



---

**Masters Staunton Chess Set / GR027**

M. Ø 4,5 x 12 cm, 1,70 x 4,50"

---



---

**Dice Box With 5 Dices, Silver / GR031**

M. 6,50 x 6,50 x 6,50 cm, 2,60 x 2,60 x 2,60"

---



---

**Dice Box With 5 Dices, Brass / GR030**

M. 6,50 x 6,50 x 6,50 cm, 2,60 x 2,60 x 2,60"

---

# Dutch Domino

Possibly the most unusual domino game in the world. The original was carved in ivory by a Dutch Renaissance artist. Unique gift, historical décor.

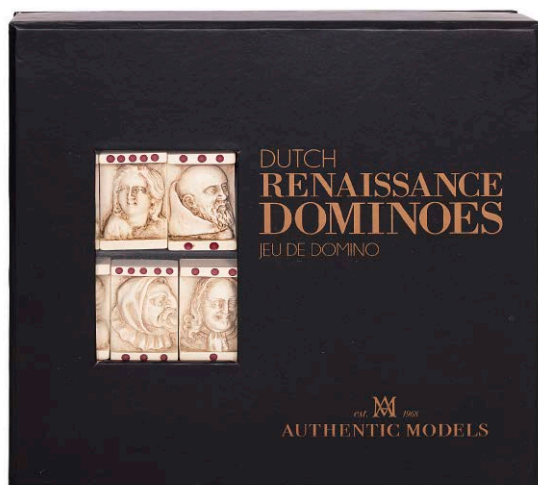

\*Gift packaged

## Domino Game / GR032

M. 0,20 x 0,19 x 0,04 cm, 7,75 x 7,30 x 1,30"

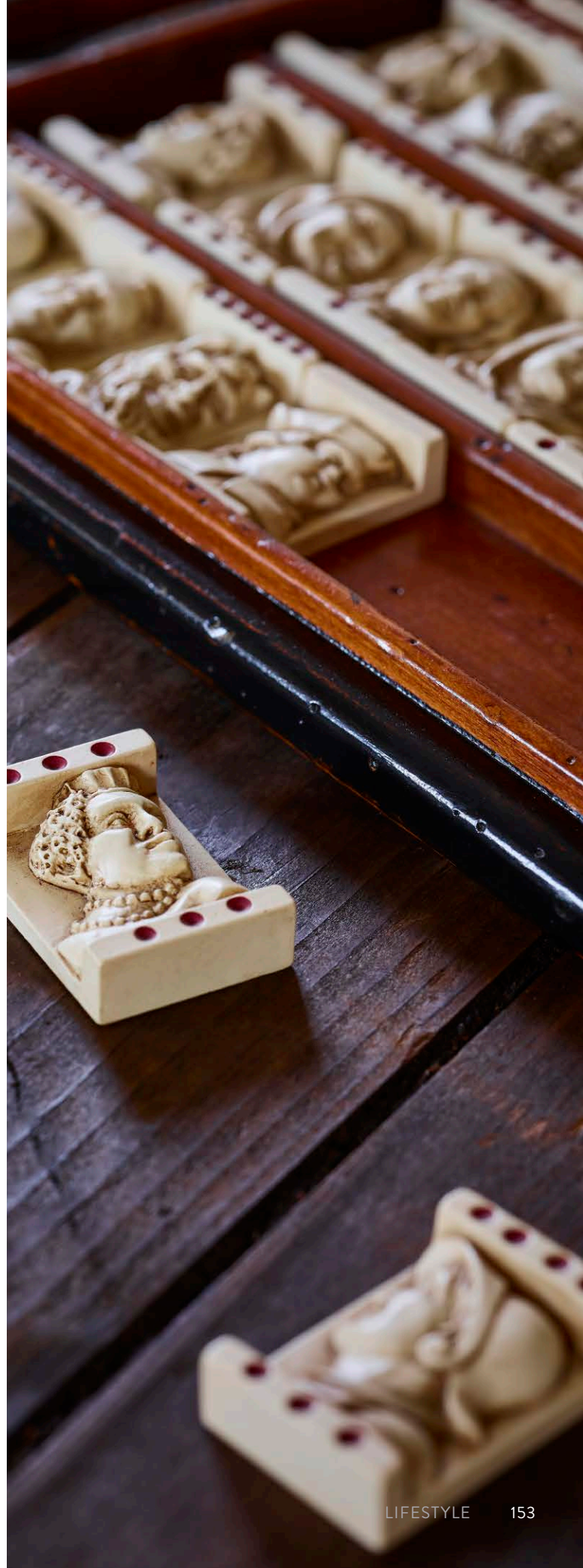



**Windsor Prose / MG029**

M. 29,20 x 7,80 x 8 cm, 11,50 x 3,10 x 3"



**Windsor Travel, Blue / MG127**

M. 29,20 x 7,80 x 8 cm, 11,50 x 3,10 x 3"



**Campaign Lap Desk / MG076F**

M. 40,50 x 25,50 x 10cm, 15,90x 10 x 3,90"

French finish distressed, bronze hinges, secret hiding spots, special place for inkwells, styluses and lots of papers. Accessories include two belle epoque styluses and bottle of black ink. Classic campaign accessory.



**Trianon Travel, Black / MG128**

M. 26,40 x 18,50 x 6,25cm, 10,40 x 7,30 x 2,50"



**Trianon Letters / MG059**

M. 36,80 x 15,70 x 6,25cm, 14,50x 6,20 x 2,50"

Enjoy our writing instruments to write real letters that impart both romance and a talent for perception along with a turn of phrase. Compose a meaningful letter that will delight. Poetry flows freely when one has a quill in hand. Nibs, wood stylus and ink included.



**Feather Pen Set / MG118**

M. 25,50 x 8,50 x 6,50cm, 10 x 3,30x 2,60"



**Colorful Prose / MG084**

M. 25,60 x 8,90 x 7 cm, 9,30 x 3,50 x 2,60"



**Palette For Pens 2 / MG083**

M. 25,60 x 8,90 x 7 cm, 9,30 x 3,50 x 2,60"

“The pen is the tongue of the mind.”





# INSTRUMENTS

Before the technological revolution, intrepid explorers depended on finely calibrated analogue instruments to measure time, assess weather, read maps, survey surroundings and identify direction. Capturing their spirit of adventure, Authentic Models' fully functioning compasses, visionary aids, time-pieces and weather measuring devices pay homage to the significance of these inventions. Our skilfully crafted pieces charm in their aesthetic beauty while allowing you to put your own skills to the test.



“Live your life  
by a compass  
not a clock.”

A compass offers the most significant message to the recipient in the smallest, most interesting package possible. It's a symbol for direction, staying the course, for adventure, discovery, science and human inventiveness.



\*Gift packaged

**Small Compass, Bronzed / CO002B**

M. 4,70 x 6 x 1,50 cm, 1,85 x 2,40 x 0,60"



\*Gift packaged

**Pocket Compass / CO003**

M. 8,50 x 10 x 1,50cm, 3,30 x 3,90 x 0,60"



\*Gift packaged

**Small Compass / CO002**

M. 4,70 x 6,50 x 1,50 cm, 1,85 x 2,60 x 0,60"



\*Gift packaged

**WWII Compass / CO014**

M. Ø 5,50 x 2 cm, 2,20 x 0,80"



\*Gift packaged

**Victorian Trails Compass / CO007**

M. 6 x 7,5 x 1,75 cm, 2,40 x 2,95 x 0,70"



**Lifeboat Compass / CO015**



This travel sundial needs a compass to find north. Raising the triangular gnomon upright while pointing the compass needle North will show the time. Bronze dry compass, hand colored reproduction compass cards.



\*Gift packaged

**18th C. Sundial & Compass / CO012A**

M. Ø 8,50 x 2,50 cm, 3,30 x 1"



**Mariner's Compass / CO019**

M. Ø 9 x 3 cm, 3,60 x 1,15"



\*Gift packaged

**Polaris Compass / CO027**

M. Ø 5,80 x 1,70 cm, 2,30 x 0,68"



**Lifeboat Compass / CO015**

M. 12 x 12 x 8,50 cm, 4,70 x 4,70 x 3,30"



\*Gift packaged

**Lewis & Clark Compass / CO009**

M. 7,75 x 7,75 x 2,25 cm, 3,10 x 3,10 x 0,90"



**Navigator's Box / CO018**

M. Ø 9 x 4 cm, 3,50 x 1,60"

Through centuries of technological innovation, we've charted the whole world. But early navigators and explorers setting out didn't necessarily know where they were headed. Guided only by a simple compass, the stars of the night sky, early octants and astrolabes. Possibly terrifying, but also exciting... Discover early navigation, enjoy an unbelievable collection of compasses from various eras.



AUTHENTIC  
NEW  
MODELS

\*Gift packaged

**Eye Compass Large / CO032**

M. Ø11,30 x 4,10 cm, 4,45 x 1,60"



AUTHENTIC  
NEW  
MODELS

\*Gift packaged

**Slide Out Compass / CO035**

M. Ø 7 x 2,85 cm, 2,75 x 1,12"



AUTHENTIC  
NEW  
MODELS

\*Gift packaged

**Eye Compass Small / CO034**

M. Ø 5,90 x 2,90 cm, Ø 2,35 x 1,15"



AUTHENTIC  
NEW  
MODELS

\*Gift packaged

**Antique Pocket Compass / CO036**

M. Ø 5,60 x 1,85 cm, 2,20 x 0,70"



AUTHENTIC  
NEW  
MODELS

\*Gift packaged

**Eye Compass Medium / CO033**

M. Ø 8,20 x 3,40 cm, 3,25 x 1,35"



\*Gift packaged

**18th C. Compass-Sundial, small / CO028**

M. Ø 5,50 x 1,50 cm, 2,15 x 0,60"

“Don't count  
the days make  
the days count.”

An early, simple pocket calculator from an era when 40-50 years were akin to perpetual. Its origin goes back some 500 years. Calculate the day of the week for any given future date, within a 40-year or 50-year span. To use, simply rotate dial until the selected year lines up with the selected month. Locate the particular date and find the day of the week above it.



“The time is now.”



**Bronzed 30 minute Hourglass / HG007**

M. Ø 8 x 13,50 cm, 3,10 x 5,30”



**Silver 30 minute Hourglass / HG007S**

M. Ø 8 x 13,50 cm, 3,10 x 5,30”



\*Gift packaged

**Brass 3 minute Sandglass / HG001**

M. Ø 3,50 x 9,50 cm, 1,40 x 3,70”



\*Gift packaged

**Bronze 3 minute Sandglass / HG001B**

M. Ø 3,50 x 9,50 cm, 1,40 x 3,70”



**Bronzed 30 min Hourglass with Stand / HG008**

M. 18,50 x 13 x 25,50 cm, 7,30 x 5,10 x 10”



**Silver 30 min Hourglass with Stand / HG008S**

M. 18,50 x 13 x 25,50 cm, 7,30 x 5,10 x 10”



Collectable because of their combined historical and practical value. Ship's hourglasses were calibrated to the half hours of the ship's watch. To appreciate the important symbolism of the hourglass, Renaissance artists painted still lifes which were also called Vanitas, filled with symbolism and morals. They very often depict hourglasses.



**Sand timer short / SD008**

M. Ø 11 x 13,50 cm, 4,60 x 5,30"



**Sunny Hours / CO026**

M. 5,10 x 5,10 x 12,50 cm, 2 x 2 x 5"



**FitzRoy's Storm glass / SD001**

M. 8,50 x 5,80 x 14,80 cm, 3,40 x 2,30 x 5,80"



AUTHENTIC  
NEW  
MODELS

**Liquid Hour Glass, 3 min / HG009**

M. Ø 6,80 x 20 cm, 2,70 x 7,90"



**Crooks radiometer round shape big / SD005**

M. Ø 9,50 x 22 cm, 3,95 x 8,90"

# Eye of Time

Victorian engineers loved to tinker with design, and make things look interesting and especially larger than life. A pocket watch transformed into a desk watch, convex optical glass magnifiers showing an enlarged dial and hands. Not exactly a travel watch this, more desk bound, an object that delights with its translation of form. Turning into a gem under soft lamp light, it doesn't easily get lost while always telling time. Combine various time zones to function as a richly nostalgic, gracious world time clock.



\*Gift packaged

## Eye of Time / SC050

M. Ø 5 x 8 cm, 2 x 3,10"

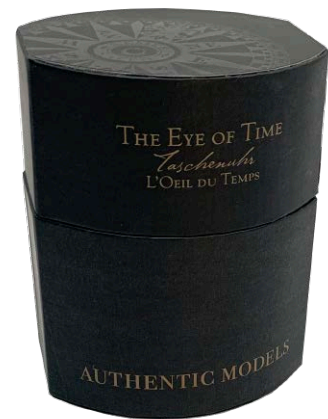

\*Gift packaged

## Porthole Eye of Time, Bronze / SC055

M. 6,20 x 7,10 x 5 cm, 2,45 x 2,80 x 2"



## Desk Stand Gor Globe / GL000

M. Ø 11 x 17,50 cm, 4,30 x 6,90"



\*Gift packaged

---

**Eye of Time, Library / SC052**

M. Ø 7,50 x 11,50 cm, 3 x 4,50"

---



**Eye of Time, Library / SC052**  
**Stand For Eye of Time, Library / GL000L**



---

**Stand For Eye of Time, Library / GL000L**

M. 13 x 7,50 x 27,50 cm, 5,10 x 3 x 10,80"

---

The interior of a plane's cockpit may be overwhelming to most, but is an irresistible attraction for aviation fans. For those who simply can't get enough of the romance of flying, we're bringing it home in the form of a functioning clock presented to look like an altitude meter.



AUTHENTIC  
NEW  
MODELS

\*Gift packaged

**Eye of Time Clock, Silver / SC063**

M. Ø 7,50 x 11,50 cm, 3 x 4,50"



**Altitude Clock / SC060**

M. 11,70 x 17,50 x 10 cm, 4,60 x 6,90 x 3,95"



AUTHENTIC  
NEW  
MODELS

**Eye of Time Clock, XL / SC064**

M. Ø 10 x 13,50 cm, 4,25 x 5,50"



AUTHENTIC  
NEW  
MODELS

**Eye of Time Clock, XXL / SC065**

M. Ø 13 x 16,50 cm, 5,50 x 6,75"



AUTHENTIC  
NEW  
MODELS

\*SC063 (as shown from the backside) sold separately

**Stand Library Clock, Silver / GL000S**

M. 13 x 7,50 x 27,50 cm, 5,10 x 3 x 10,80"



Altitude Clock / SC060



Art Deco Flight Clock / AP104

M. 35,50 x 7 x 10 cm, 14 x 2,80 x 4,10"



Propeller Clock / AP111

M. 30,50 x 5,50 x 9,50 cm, 12 x 2,20 x 3,70"



\*Gift packaged

Eye of Time, Nickel / SC051

M. Ø 5 x 7,10 cm, 2 x 2,80"



Stand For Eye of Time, Nickel / GL000C

M. Ø 11 x 17,50 cm, 4,30 x 6,90"



• AUTHENTIC  
NEW  
MODELS •

**Desk Clock / SC046**

M. 11 x 6,85 x 10,65 cm, 4,30 x 2,70 x 4,20"



**Victorian Dome Watch / SC054**

Ø 13,50 cm / 5,30" M. 13,50 x 13,50 x 12,50 cm, 0 x 0 x 4,90"



**Savoy Pocket Watch / SC057**

M. 5 x 1,20 x 6,60 cm, 2 x 0,50 x 2,60"



**Victorian Pocket Watch / SC058**

M. 5,10 x 1,40 x 6,80 cm, 2 x 0,55 x 2,65"

A classical naval WW II era timepiece, designed in accordance with military specifications. Its unusual two-piece configuration has a hinged front section that swings open to access the movement and rear-mounting bracket. The sturdy original was faithfully tended for weekly winding and regulation. With the modern movement provided, our Navy Clock's only attendant requirement is the possessor's admiration!



**Navy Clock / SC048**

M. Ø 16 x 10,25 cm, 6,25 x 4"



**Porthole Clock, Aluminum / SC043**

M. Ø 15 x 5 cm, 5,90 x 2"



• AUTHENTIC  
NEW  
MODELS •

**World Clock Madison / SC062**

M. 22,20 x 7 x 17,20 cm, 8,75 x 2,75 x 6,75"

# Collector Objects

Magnifiers are fashionable collector's objects and have become popular accessories accenting a well-dressed coffee or side table.



**Magnifying Glass With Tripod / AC040**  
M. 17 x 17 x 34 cm, 6,70 x 6,70 x 13,40"



\*Magnifiers sold sepeately

**Magnifier Stand / AC000**  
M. 50 x 19 x 39,50 cm, 19,75 x 7,75 x 15,50"



**Oxford Magnifier / AC091**  
M. 17 x 6,50 x 2,50 cm, 6,70 x 2,60 x 1"



**Mini Magnifier / AC092**  
M. 6,20 x 3,90 x 0,50 cm, 2,45 x 1,50 x 0,20"



My earliest glass was a utilitarian Boy Scout one of sturdy brass. I studied insects and the skin of my hand. However, after turning my dad's newspaper into charcoal, it was confiscated, despite me protestation that the glass was an essential tool of scientific discovery. Our discovery glass allows detailed examination of maps, coins, and other wonders.



**Discovery Glass / CO004**  
M. Ø 5,50 x 1,25 cm, 2,20 x 0,50"



\*Gift packaged



**Vintage Travel Magnifier / AC090**  
M. 13 x 5,50 x 1,90 cm, 5,25 x 2,25 x 0,75"

# Desk Magnifier

It always pays to have a close look! That picture of grandmother in a group of 27 classmates, from 1919. Did she wear earrings? A tool for the curious of mind. Practical, authentic, and highly decorative. This desk magnifier has a nice brass finish.



**Desk Magnifier 3", Brass / AC044**

M. Ø 8 x 5,50 cm, 3,15 x 2,17"



**Desk Magnifier 3", Pewter / AC047**

M. Ø 8 x 5,50 cm, 3,15 x 2,17"



**Desk Magnifier 4", Brass / AC043**

M. Ø 10,50 x 7 cm, 4,15 x 2,75"



**Desk Magnifier 4", Pewter / AC046**

M. Ø 10,50 x 7 cm, 4,15 x 2,75"



**Desk Magnifier 5", Brass / AC042**

M. Ø 13,50 x 9 cm, 5,30 x 3,55"



**Desk Magnifier 5", Pewter / AC045**

M. Ø 13,50 x 9 cm, 5,30 x 3,55"

Conversation has had its prescribed etiquette. During the late Victorian era and into the Belle Époque one's monocle served to intimidate and disadvantage. A houseguest who overstayed his welcome... an unwelcome suitor to a favorite daughter? Now a tool to study the lines on your palm, a picture, fingerprints or small print. A gift with excellent provenance, an accessory that delivers.



**Empress Reading Glass / AC095**

M. 23,50 x 8 x 20,50 cm, 9,30 x 3,10 x 8,10"



\*Gift packaged

**Magnifying Glass / AC099**

M. 25 x 10 x 2,50 cm, 9,80 x 3,90 x 1"



**Magnifying Glass With Stand / AC099A**

M. 25 x 11,50 x 18 cm, 9,80 x 4,50 x 7,10"



\*Gift packaged

**Magnifying Glass, Bronzed / AC099B**

M. 25 x 10 x 2,50 cm, 9,80 x 3,90 x 1"



**Magnifying Glass With Stand, Bronzed / AC099E**

M. 25 x 11,40 x 18 cm, 9,80 x 4,50 x 7,10"



\*Gift packaged

**Nickel Magnifying Glass / AC098**

M. 32 x 8,50 x 2 cm, 12,60 x 3,30 x 0,80"

It always pays to have a close look! The signature on the painting you just purchased at that out-of-the-way estate sale. Check on your hunch it's a Leonardo... Or study the hallmarks on the sterling polo trophy you took from that weekend trip to Buenos Aires. Or just retrace Sherlock's trails in London's Chelsea. Fingerprints, hair and fibers? You need The Glass!!



\*Gift packaged

---

**Regency Magnifier / AC109**

M. 27 x 11,40 x 1,20 cm, 10,60 x 4,50 x 0,50"

---



\*Gift packaged

---

**Regency Magnifier, Silver / AC109S**

M. 26,50 x 11,50 x 1,20 cm, 10,40 x 4,50 x 0,50"

---



---

**Rococo Magnifier, Bronze / AC113**

M. 13 x 5,25 x 1 cm, 5,10 x 2,10 x 0,40"

---



---

**Rococo Magnifier, Silver / AC114**

M. 13 x 5,25 x 1 cm, 5,10 x 2,10 x 0,40"

---



---

**Reader's Glass / AC116**

M. 22,50 x 8 x 2,50 cm, 8,90 x 3,10 x 1"

---



\*Gift packaged

---

**Magnifying Glass, Silver / AC099S**

M. 25 x 10 x 2,50 cm, 9,80 x 3,90 x 1"

---



A sleeker interpretation of the design style popular during the Victorian era, these fully functional small opera glasses have both ornamental and practical value. An appealing gift for those with an interest in theatre or iconic visual aids, and an attractive display object for interiors themed around these subjects.



• AUTHENTIC  
NEW  
• MODELS



• AUTHENTIC  
NEW  
• MODELS

**Opera Binocular Silver 3" / KA033**

M. 11,50 x 8 x 5 cm, 4 x 2,50 x 2"

**Opera Binocular Silver 4" / KA034**

M. 16 x 12 x 5 cm, 4,50 x 4,25 x 2"

Charming sextants as used by Victorian explorers and surveyors. Intricate and semi-functional, it has all the pieces needed to shoot the sun. A sextant defined latitude. A clock longitude. Defining the angle of Sun and Stars with the horizon was an important way to navigate and survey. A beautiful intricate little instrument with an interesting and ancient history.



**Bronze Pocket Sextant / KA030**

M. 11 x 11 x 6 cm, 4,25 x 4,25 x 2,24"



**Sextant in Case / KA0232**

M. 15 x 15 x 8 cm, 6 x 6 x 3,25"



**Royal Dockyard Tape Measure / KA037**

M. Ø 14 x 3 cm, 5,50 x 1,20"



**Victorian Binoculars, Bronze / KA026**

M. 11,70 x 12,50 x 5,60 cm, 4,60 x 4,90 x 2,20"



**Victorian Binoculars with Tripod, Silver / KA025S**

M. 16,50 x 14 x 41,50 cm, 6,50 x 5,50 x 16,30"

Binoculars were a Victorian invention and were much easier to use than the one lens drawn out telescope. Sturdy 19th C. binoculars on elegant beautifully crafted mini-tripod.



**Victorian Binoculars With Tripod / KA025**

M. 16,50 x 14 x 41,50 cm, 6,50 x 5,50 x 16,30"

An intriguing and classic explorer's and navigator's tool. The telescope consists of a wood or metal barrel holding an objective, a system of lenses. It is protected by metal collars and a decorative cap while the smallest tube holds the eye objective.



**Bronze Spyglass / KA023**

M. 46 x 5,50 x 5,50 cm, 18,10 x 2,20 x 2,20"



**Silver Spyglass / KA023L**

M. 54 x 17 x 11 cm, 21,30 x 6,70 x 4,30"



**Leather Spyglass / KA029**

M. 41 x 5 x 5 cm, 16,20 x 2 x 2"



**Officer's Spyglass / KA036**

M. Ø 4,25 x 38,75cm, 1,70 x 15,30"



**Officer's Spyglass, Silver / KA036S**

M. Ø 4,25 x 38,75cm, 1,70 x 15,30"



**Bronze Spyglass & Stand, French Finish / KA023F**

M. 54 x 17 x 11 cm, 21,30 x 6,70 x 4,30"



Magnification 35x

## Observe wildlife

After dinner, having enjoyed a chilled Chardonnay, nothing is more relaxing than observing birds and wildlife or neighbors with a tripod mounted telescope... Instrument in quality brass and stand in rich wood, with adjustable legs and solid brass fittings.

---

### Avalon Telescope / KA038

M. 100 x 82 x 156,25 cm, 39,40 x 32,30 x 61,50"

---



Monocular on Tripod / KA039



## Handsewn Leather

This astonishing monocular is outfitted with complicated prismatic lenses. Its brass and nickel parts are expertly covered with handsewn leather, to withstand the wear and tear of daily use on campaign.

Magnification 20x

---

**Monocular on Tripod / KA039**  
M. 96 x 96 x 170 cm, 37,80 x 37,80 x 67"

---



**Grand Hotel Rack / MF132**

# HOW TO REACH US

---

## AUTHENTIC MODELS HEAD OFFICE GLOBAL

---



### Authentic Models BV

Ambachtsweg 37

3899 AM Zeewolde The Netherlands

Phone +31-(0)36-52 19 191

Fax +31-(0)36-52 19 170

sales.eu@authenticmodels.com

---

## SALES OFFICES EUROPE

---



### Authentic Models Belgium

Phone +32-(0)22 45 67 50

Phone +31-(0)36 52 191 76

am-belgium@authenticmodels.com



### Authentic Models Germany (DACH)

Phone +31-(0)36 52 191 73

sales.eu@authenticmodels.com



### Authentic Models France

Phone +31-(0)36 52 191 82

sales.eu@authenticmodels.com



### Authentic Models Italy

Phone +39-(0)35-910 827

Phone +31-(0)36 52 191 76

am-italy@authenticmodels.com



### Authentic Models Spain

Phone +34-93 81 24 366

Phone +31-(0)36 52 191 76

am-spain@authenticmodels.com



### Authentic Models UK & Ireland

Phone +44-(0)1403-734 999

am-uk@authenticmodels.com



---

## OFFICE UNITED STATES

---



### Authentic Models Americas Inc.

888 Garfield Street

P.O. Box 21710 Eugene, OR 97402

Phone 541-686-4666

Toll-Free 800-888-1992

Fax 541-686-5111

sales.usa@authenticmodels.com

### Showroom USA

Space #13-D-7; E-3A

40 John Portman Blvd. NW

Atlanta, Georgia 30303

---

## SALES OFFICE AUSTRALIA

---



### AM Living Australia

Ground Floor, 390 Mount Alexander Road

Ascot Vale, VIC 3032 Australia

Phone 61-03-9326-0140

info@amliving.com.au

---

## JOIN US ONLINE

---



instagram.com/authentic.models



facebook.com/AMAAuthenticModels



pinterest.com/am7394

#AUTHENTICMODELS

SHARE YOUR FAVORITES WITH US



Polo Club Bar, Black / MF114

# INDEX



Armillaries	129	Magnifiers	169 - 173
Balloons	74 - 85	Mirrors	148 - 149
Bars	8 - 15	Mobiles	73, 76 - 77, 102, 126, 127
Bookcases	26 - 28, 32 - 41	Nautical fun	103, 144
Cabinets	30 - 41	Oars	100 - 101
Cars	104 - 113	Plane models	52 - 61, 64 - 65
Chairs	42 - 45	Propellers	66 - 72
Classic Decor	132 - 139	Runabouts	94 - 97
Compasses	158 - 161	Sailing ships	88 - 93, 102
Desks	20 - 23, 25	Steamers	98 - 99
Desktop planes	62 - 63	Stools	42 - 43
Dressing	29	Sundials	159, 160, 163
Games	140 - 141, 150 - 153	Tables	15 - 19
Globes	114 - 125	Telescopes	174 - 179
Globe stands	128	Time	162 - 168
Hospitality	145 - 147	Weather	163
Lanterns	142 - 143	Writing	154 - 155

## **COPYRIGHT**

No part of this publication may be reproduced in any manner of form whatsoever without the prior written permission of Authentic Models and other copyright holders. No rights can be derived from this publication.

## **DISCLAIMER**

Authentic Models makes every effort to maintain the accuracy and quality of the information provided in this catalogue. However, Authentic Models cannot guarantee and assumes no legal liability or responsibility for the accuracy or completeness of the information provided. It is important to bear in mind that the colours shown in this catalogue may not be accurate representations of the actual colours of the items. The colour reproduction in this catalogue should only be used as a rough guide for selecting item colours.

## **UNIQUE PRODUCTS**

Some products in the Authentic Models collection are handcrafted from natural materials. This means products are rarely completely identical and may show variance in colour, size or finish. We believe this aspect adds to the value and quality of these products. Small irregularities in shapes, surfaces and finishes are hallmarks of hand-craftsmanship and should not be considered defects.

## **COPYRIGHT**

Aucune partie de cette publication ne peut être reproduite de quelque manière ou sous quelque forme que ce soit sans l'autorisation écrite préalable d'Authentic Models et d'autres détenteurs de droits d'auteur. Aucun droit ne peut être dérivé de cette publication.

## **AVIS DE NON-RESPONSABILITÉ**

Authentic Models BV met tout en œuvre pour maintenir l'exactitude et la qualité des informations fournies dans ce catalogue. Toutefois, Authentic Models ne peut garantir et n'assume aucune responsabilité légale concernant l'exactitude ou l'exhaustivité des informations fournies.

Il est important de garder à l'esprit que les couleurs illustrées dans ce catalogue peuvent ne pas être des représentations exactes des couleurs réelles des articles. La reproduction des couleurs dans ce catalogue ne doit être utilisée que pour vous guider dans le choix des couleurs des articles.

## **DES PRODUITS UNIQUES**

Certains produits de la collection Authentic Models sont fabriqués à la main à partir de matériaux naturels. Cela signifie que les produits sont rarement totalement identiques et peuvent présenter des différences de couleur, de taille ou de finition. Nous estimons que cet aspect ajoute de la valeur et de la qualité à ces produits. De petites irrégularités dans les formes, surfaces et finitions sont caractéristiques du travail artisanal et ne doivent pas être considérées comme des défauts.

## **COPYRIGHT**

Kein Teil dieser Veröffentlichung darf ohne vorherige schriftliche Zustimmung von Authentic Models und anderen Urheberrechtsinhabern auf irgendeine Weise oder in irgendeiner Form reproduziert werden. Aus dieser Veröffentlichung können keine Rechte abgeleitet werden.

## **HAFTUNGSAUSSCHLUSS**

Authentic Models BV bemüht sich nach Kräften, die Richtigkeit und Qualität der in diesem Katalog enthaltenen Informationen sicherzustellen. Authentic Models kann allerdings die Richtigkeit oder Vollständigkeit der vorgelegten Informationen nicht garantieren und übernimmt diesbezüglich keine gesetzliche Haftung oder Verantwortung.

Es ist wichtig zu berücksichtigen, dass die in diesem Katalog gezeigten Farben die tatsächlichen Farben der Artikel eventuell nicht genau wiedergeben. Die Farbwiedergabe in diesem Katalog sollte lediglich als grober Anhaltspunkt bei der Auswahl farbiger Artikel genutzt werden.

## **UNIKATE**

Einige Produkte in der Kollektion von Authentic Models werden aus natürlichen Materialien von Hand hergestellt. Das bedeutet, dass die Produkte nur selten vollständig identisch sind und sich eventuell in Bezug auf Farbe, Größe oder Oberflächengestaltung voneinander unterscheiden. Wir sind davon überzeugt, dass dies zum Wert und zur Qualität dieser Produkte beiträgt. Geringfügige Abweichungen in Bezug auf Formen, Oberflächen und Endbearbeitung sind Kennzeichen der Fertigung von Hand und sollten nicht als Mängel betrachtet werden.